

# **ACTURA Flex 48330 Power System**

## **User Manual**

Version: V1.0  
Revision date: May 20, 2005  
BOM: 31011084

---

Emerson Network Power provides customers with technical support. Users may contact the nearest Emerson local sales office or service center.

Copyright © 2005 by Emerson Network Power Co., Ltd.

All rights reserved. The contents in this document are subject to change without notice.

Emerson Network Power Co., Ltd.

Address: No.1 Kefa Rd., Science & Industry Park, Nanshan District  
518057, Shenzhen China

Homepage: [www.emersonnetworkpower.com.cn](http://www.emersonnetworkpower.com.cn)

E-mail: [support@emersonnetwork.com.cn](mailto:support@emersonnetwork.com.cn)

## **Safety Precautions**

To avoid accident, read the safety precautions very carefully before operation. The "Caution, Notice, Warning, Danger" in this manual do not represent all the safety points to be observed. Therefore, the installation and operation personnel must be strictly trained and master the correct operations and all the safety points before actual operation.

When operating Emerson products, the safety rules in the industry, the general safety precautions and special safety instructions must be strictly observed.

## **Electrical Safety**

### **1. Hazardous voltage**

Some components of the power system carry hazardous voltage in operation, direct contact or indirect contact through moist objects with these components will result in fatal injury.

Safety rules in the industry must be observed when installing the power system. The installation personnel must be licensed to operate high voltage and AC power.

In operation, be sure to remove conductive objects, such as watch, bracelet, ring, and so on.

When water or moisture is found on the cabinet, turn off the power immediately. In moist environment, take precautions to keep moisture out of the power system.

"Prohibit" warning label must be attached to the switches and buttons which are not permitted to be operated on during installation.

High voltage operation may cause fire and electric shock. The connection and wiring of AC cables must be in compliance with the local codes and regulations. Only those who are licensed to operate high voltage and AC power can perform high voltage operations.

### **2. Tools**

In high voltage and AC operation, special tools must be used. No common or homemade tools should be used.

### **3. Thunderstorm**

Never operate on high voltage, AC, iron tower or mast on a day with thunderstorm.

In thunderstorms, a strong electromagnetic field will be generated in the air. Therefore the equipment should be well-earthed in time to avoid damage by lightning strikes.

#### 4. ESD

The static electricity generated by the human body will damage the static sensitive elements on PCBs, such as large-scale ICs. Before touching any plug-in board, PCB or IC chip, ESD wrist strap must be worn to prevent body static from damaging the sensitive elements. The other end of the ESD wrist strap must be well earthed.

#### 5 Short-circuit

During operation, never short the positive and negative terminals of the MFU of the system or the non-earthing terminal and the earth. The power system is a constant voltage DC power equipment, short circuit will result in equipment burning and endanger human safety.

Check carefully the polarity of the cable and connection terminal when performing DC live operations.

Never wear a watch, bracelet, ring, or other conductive objects during operation.

Insulated tools must be used.

#### **Battery**

Before any operation on battery, read very carefully the safety precautions for battery transportation and the correct battery connection method.

Non-standard operation on the battery will cause danger. In operation, precautions should be taken to prevent battery short circuit and overflow of electrolyte. The overflow of electrolyte will pose potential threat to the equipment, it will erode the metal objects and PCBs, thus causing equipment damage and short circuit of PCBs.

Before any operation on battery, pay attention to the following points:

Remove the watch, bracelet, bangle, ring, and other metal objects on the wrist.

Use special insulated tools.

Wear an eye protection device, and take preventive measures.

Wear rubber gloves and apron to guard against electrolyte overflow.

In battery transportation, the electrode of the battery should always be kept facing upward. Never put the battery upside down or slanted.

### **Special Safe Requirements of This Equipment**

The equipment has multi power inputs;

The equipment shall be installed on cement ground.

### **Others**

#### 1 Safety requirement

Please use the same model fuse to replace the fuse in the DC Power System.

#### 2. Sharp object

When moving equipment by hand, wear protective gloves to avoid injury by sharp object.

#### 3. Cable connection

Please verify the compliance of the cable and cable label with the actual installation prior to cable connection.

#### 4. Binding the signal cables

The signal cables should be installed separately far away from heavy current and high voltage cables, with distance at least 150mm.

# Contents

Chapter 1	System Description.....	1
1.1	Abbreviation.....	1
1.2	Introduction .....	1
1.3	Features.....	1
1.4	System Configuration.....	2
1.5	Components.....	4
1.5.1	Rectifier Shelf.....	4
1.5.2	Rectifier.....	6
1.5.3	SCU .....	7
1.5.4	Multi-Function Unit (MFU).....	9
1.5.5	Battery Connection Unit (BCU) .....	10
1.5.6	System Cabinet.....	11
Chapter 2	Installation .....	12
2.1	Installation Preparation .....	12
2.1.1	Environmental Conditions .....	12
2.1.2	Power Supply.....	12
2.1.3	Site Survey .....	13
2.1.4	Tools & Material.....	13
2.1.5	Unpacking.....	14
2.2	Installation Procedures.....	15
2.2.1	Cabinet Installation .....	15
2.3	External Electrical Connection Interface .....	17
2.3.1	Connection Of Input Cables.....	17
2.3.2	Connection Of Load Cables.....	20
2.3.3	Connection Of Communication Cables .....	21
2.3.4	Layout Of Connector Board S6415X2.....	22
2.3.5	Interface Definition Of Connector Board S6415X2.....	23
2.3.6	Connection Of Temperature Sensor Cables .....	24
2.3.7	Connection With MODEM.....	24
2.3.8	Connection With Dry Contacts .....	25
2.4	Battery Installation And Cabling.....	25
2.4.1	Battery Installation .....	25
2.4.2	Battery Cable Connection .....	26
2.5	Parallel Connection Of Cabinets .....	29
Chapter 3	Startup.....	30
3.1	Checking Before Startup .....	30
3.2	Startup Process .....	31
3.3	Parameters Configuration .....	31

Chapter 4	Testing.....	32
4.1	Testing MFU .....	32
4.2	Testing Rectifier .....	32
4.3	Testing SCU.....	32
4.4	Battery Breaker Test .....	33
4.5	BCU Test .....	33
4.6	Load Breaker Test .....	33
Chapter 5	Operating SCU .....	34
5.1	Operation Panel .....	34
5.2	Operation Procedures .....	35
5.3	Querying System Status .....	36
5.3.1	First Page Of System Information .....	36
5.3.2	Other System Information Screen.....	37
5.4	Querying Rectifier Status .....	39
5.5	Querying Alarms And Setting Alarm Plans.....	40
5.5.1	Querying Active Alarm .....	40
5.5.2	Query Alarm History.....	41
5.5.3	Alarm Type Table.....	43
5.5.4	Changing Audible/Visual Alarm And Alarm Call Back Plan.....	46
5.5.5	Changing Alarm Types Of Dry Contacts .....	46
5.5.6	Setting Alarm Type For Dry Contacts .....	46
5.5.7	Set the Alarm Names Through PLC Function .....	48
5.6	Maintenance .....	51
5.7	Setting System Parameters .....	53
5.7.1	Parameter Setting Method .....	53
5.7.2	Batt. Selection.....	55
5.7.3	LVD Parameter Description .....	56
5.7.4	Charging Management Parameters .....	57
5.7.5	Battery Test Parameters .....	60
5.7.6	Temperature Compensation Coefficient Parameters .....	62
5.7.7	AC Settings.....	63
5.7.8	DC Setting .....	64
5.7.9	Rect Settings .....	65
5.7.10	System Settings.....	66
5.7.11	Alarm Settings.....	70
Chapter 6	Routine Maintenance.....	72
6.1	Maintenance Of Rectifier.....	72
6.2	Maintenance Of SCU .....	72
6.3	Maintenance Of MFU .....	72
6.4	Cover Plates .....	73
6.5	Battery Maintenance .....	73
6.5.1	Storage And Supplementary .....	73

6.5.2	Daily Inspection.....	73
6.5.3	Replacement.....	74
Chapter 7	Troubleshooting.....	75
7.1	Troubleshooting Rectifier .....	75
7.2	Mains Failure .....	76
7.3	Disastrous Accidents .....	76
Appendix 1	System Technical Parameters .....	77
Appendix 2	Engineering Design Diagram .....	79
Appendix 2.1	Engineering Design Diagram For 2000mm%600mm%600mm Cabinet ..	79
Appendix 2.2	Engineering Design Diagram For 2000mm%600mm%400mm Cabinet ..	80
Appendix 2.3	Engineering Design Diagram For 700mm%600mm%400mm Cabinet ....	81
Appendix 2.4	System Input And Output Connector Specs.....	81
Appendix 3	System Circuit Diagram.....	82
Appendix 3.1	System Electric Schematic Diagram .....	82
Appendix 3.2	System Wiring Diagram .....	83
Appendix 3.3	MFU Electric Wiring Diagram .....	84
Appendix 3.4	BCU Electric Wiring Diagram .....	85
Appendix 4	Glossary .....	86

## Table List

Table 1-1	Configurations of Actura Flex 48330 Power System.....	3
Table 1-2	Dimensions of rectifier shelf .....	5
Table 1-3	Function of indicators.....	7
Table 1-4	Authority and default password.....	9
Table 1-5	Configuration of MFU.....	10
Table 1-6	BCU configuration.....	11
Table 2-1	Environmental conditions in power room .....	12
Table 2-2	AC input modes .....	17
Table 2-3	Configuration number of load MCBs and battery MCBs.....	20
Table 2-4	Interface definition of connector board S6415X2 .....	23
Table 3-1	System checklist before startup .....	30
Table 5-1	Functions of LED indicators .....	34
Table 5-2	Functions of SCU keys.....	34
Table 5-3	Alarm type table .....	43
Table 5-4	Changing audible/visual alarm and alarm call back plan.....	46
Table 5-5	Optional alarm types .....	47
Table 5-6	Logic matrix used for configuring 8 dry contacts .....	49
Table 5-7	Example of PLC setting.....	49
Table 5-8	PLC SN and Alarm.....	49
Table 5-9	Password levels and authorities.....	54
Table 5-10	Value description of the basic battery parameters .....	56
Table 5-11	Value description of the LVD parameters.....	57
Table 5-12	Charging management parameter value description.....	59
Table 5-13	Value description of the battery test parameters .....	61
Table 5-14	Value description of temperature compensation coefficient.....	62
Table 5-15	Value description of AC settings .....	63
Table 5-16	Value description of DC settings .....	64
Table 5-17	Value description of rectifier settings.....	65
Table 5-18	Value description of system settings.....	68
Table 5-19	Relationship between system model and system type.....	70
Table 5-20	Value description of alarm settings .....	71
Table 7-1	Troubleshooting .....	75



## Figure List

Figure 1-1	Outline .....	2
Figure 1-2	Rectifier shelf outline.....	4
Figure 1-3	Rectifier shelf with rectifiers and CU .....	4
Figure 1-4	Dimensions .....	6
Figure 1-5	Outline of SCU.....	7
Figure 1-6	Outline and components of MFU .....	9
Figure 1-7	Outline of battery connection unit (BCU).....	10
Figure 2-1	Installation dimensions of the cabinet base .....	15
Figure 2-2	Installing expansive pipe.....	16
Figure 2-3	Fixing cabinet with Tap .....	16
Figure 2-4	Cable mounted with H terminal.....	17
Figure 2-5	Connection of input terminals .....	18
Figure 2-6	Top cover.....	18
Figure 2-7	Connection of 3-phase AC power input .....	18
Figure 2-8	Connection of single-phase AC power input.....	19
Figure 2-9	Connection of dual-phase AC power input.....	19
Figure 2-10	Connection of load cables.....	20
Figure 2-11	Cable connection to MCB .....	20
Figure 2-12	Connector board in rectifier shelf .....	21
Figure 2-13	Layout of connector board S6415X2.....	22
Figure 2-14	Input/output interfaces of TD-5648DC MODEM.....	24
Figure 2-15	Cabinet with four battery strings installed .....	26
Figure 2-16	Connection of battery cables. ....	27
Figure 2-17	Positive and negative battery cables in each level.....	27
Figure 2-18	Negative battery cables connection in BCU.....	28
Figure 2-19	Parallel connection of DC power system cabinet with battery cabinet .....	29
Figure 5-1	SCU Front Panel.....	34
Figure 5-2	BC/FC switchover diagram .....	59
Figure 5-3	Schematic diagram of the test function .....	61
Figure 5-4	System model description.....	69



# Chapter 1 System Description

## 1.1 Abbreviation

AC	Alternate Current
DC	Direct Current
SCU	Standard Controller Unit
BCU	Battery Connection Unit
CSU	Central Supervision Unit
HVSD	High Voltage Shutdown
MCB	Miniature Circuit Breaker
APFC	Active Power Factor Correction
MFU	Multi-Function Unit

## 1.2 Introduction

The ACTURA Flex 48330 Power system consists of 50A rectifiers, Control Unit, Multi-Function Unit (MFU), rectifier shelf and BCU (optional).

The product is used in base station, small exchange station, satellite communication, data communication, and so on, with a strong adaptability to power network fluctuation.

This system is used as a power supply for telecom equipment with system nominal voltage of -48V and positive terminal earthed.

## 1.3 Features

The DC power system is easy-to-operate, easy-to-install and easy-to-maintain. Its main features are:

- Rectifier uses APFC technology and therefore its PF is up to 0.99;
- Wide AC input voltage range of 85~290V;
- Rectifier efficiency is at least 90%;
- Extra low EMI of rectifier and excellent EMC performance;

- High power density of rectifier;
- Rectifier has damage-free hot plugging/unplugging function, the replacement time is less than 1min;
- Rectifier has two kinds of over-voltage protection methods;
- Perfect battery management with BLVD function;
- Up to 200 PCS of historical alarms can be stored in SCU;
- Provide RS232, Modem and dry contacts communication interfaces ;

## 1.4 System Configuration

The outline of the DC Power System is illustrated in Figure 1-1:

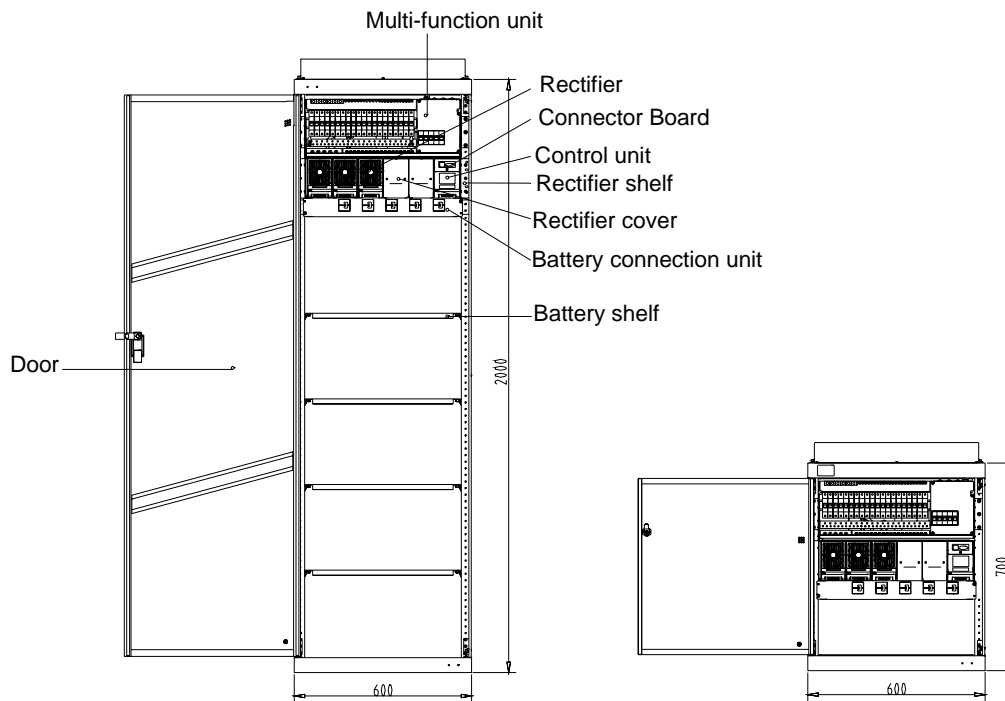

Figure 1-1 Outline

There are three kinds of DC Power Systems, and their detail configurations are as shown in Table 1-1:

Table 1-1 Configurations of Actura Flex 48330 Power System

Configuration	Cabinet dimension		
	2.0 % 0.6 % 0.6 m <sup>3</sup>	2.0 % 0.6 % 0.4 m <sup>3</sup>	0.7 % 0.6 % 0.4 m <sup>3</sup>
AC distribution	3P+N/380V AC input with SPD 3P+N/380V AC input without SPD 1P+N/220V AC input with SPD 1P+N/220V AC input without SPD L1+L2/220V AC input with SPD L1+L2/220V AC input without SPD 3P/220V AC input with SPD 3P/220V AC input without SPD 5 2P AC input MCBs Individual AC cables with just terminals		
DC distribution	Up to 28 13mm-wide MCB, or 20 18mm-wide MCB		
Rectifier	Up to 5 rectifiers		
Control unit	1 SCU		
BCU	1 BCU with up to 5 battery circuit breakers		
Battery	Telion 12V 165Ah FT: 16 Blocks Hawker 12V 155Ah FT: 16 Blocks Hawker 12V 105Ah FT: 20 Blocks Hawker 12V 105Ah FT and 6U space: 16 Blocks	Hawker 12V82F: 16 Blocks Hawker SBSC11 and 3U space: 16 Blocks EB4: 20 Blocks Hawker 12V82F( no BCU): 20 Blocks	No battery
Dimensions (HxW xD) mm	2000x600x600	2000x600x400	700x600x400

## 1.5 Components

### 1.5.1 Rectifier Shelf

#### Outline

The outline of the Rectifier Shelf is illustrated in Figure 1-2:

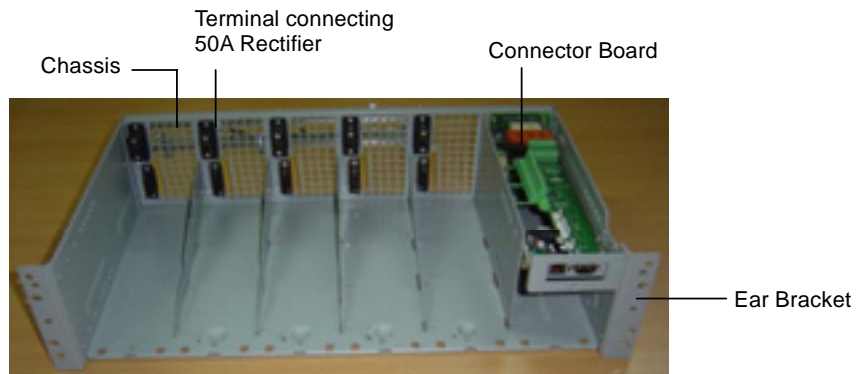

(a) Actual appearance (front view)



(b) Actual appearance (rear view)

*Figure 1-2 Rectifier shelf outline*

The shelf can accommodate 5 rectifiers and a control unit as shown in Figure 1-3. The user can mount the rectifier shelf into cabinets with widths of 600mm and depths of 400mm. The rectifier shelf has a height of 3U (132.5mm).

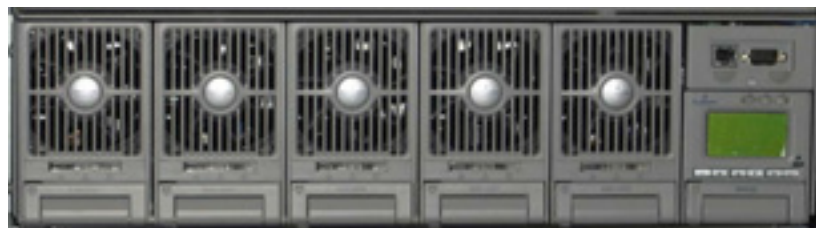

*Figure 1-3 Rectifier shelf with rectifiers and CU*

The Dimension of Rectifier Shelf are given in Table 1-2

*Table 1-2 Dimensions of rectifier shelf*

Manufacture type	W(mm) xD(mm) xH(mm)	Note
PSS485023/C	584.2x327x132.5	23" with controller

### **Backboard**

The backboard has the functions below:

- DC power source feed for controller and the connector board.
- DC input filter and input fuse.
- All the ingoing and outgoing signals of the controller

The backboard also contains system internal connectors below:

- 10 Distribution unit fuses alarm signal measurement input
- 4 battery fuse alarm signal measurement input
- 2 battery current shunt measurement inputs
- 1 load Current shunt measurement input
- System bus-bar DC Voltage measurement input
- Three-phase from two mains AC Voltage measurement inputs
- CAN communication between rectifiers and controller
- AC alarm module signals
- System fault indicator drivers
- LLVD & BLVD mono contactor driver outputs
- The entire signal outgoing to the connector board

### **Connector board**

Connector board is a user interface board and has the functions below:

- 8-channel relay outputs
- 8-channel digital inputs
- One power source feed terminal (for digital inputs)
- 2-channel temperature sensor inputs
- 2-channel RS232 parallel connection outputs
- LLVD & BLVD bistable contactor driver circuits and outputs

- One Ethernet output
- One RS485 output
- One console output for ECU debug
- The connector board can be hot plug and has enough space for accommodating all the interface cables.
- The connector board should space the hollow to the SCU convection for air flowing
- The connector board is mounted in the room 1Ux2U at the top of the SCU.
- The shelf has a 1Ux2U panel for the connector board.
- One RS232 and Ethernet ports are located at the front of the connector board.
- The shelf has two rails for supporting the connector board

## 1.5.2 Rectifier

### Outline

The appearance and dimensions (unit: mm) of the rectifier are illustrated in the following figure.



*Figure 1-4 Dimensions*

Weight:  $\leq 3.5\text{kg}$

Dimensions (H x W % D): 124.3mm % 84mm % 287mm

The functions of the indicators in front panel are listed in Table 1-3.



Table 1-3 Function of indicators

LED	Normal	Abnormal	Cause of abnormality
Power indicator (green)	ON	OFF	No AC Mains Supply
		Blinking	Rectifier is under control by SCU
Protection indicator (yellow)	OFF	ON	AC input over/under voltage, PFC over/under voltage and over temperature
		Blinking	Communication of rectifier with SCU failure
Alarm indicator (red)	OFF	ON	Output Over-voltage
		Blinking	Fan Failure

### 1.5.3 SCU

#### Outline



Figure 1-5 Outline of SCU

Dimension (H % W % D):132mm % 85mm % 287mm

Weight: 0.76kg

#### Multi-Communication mode

SCU communicates with MC (Main Computer) through the RS232/MODEM communication port and 8 groups of alarm dry contacts on the Signal Junction Board.

SCU supports both China Telecom Communication Protocol and EEM Protocol. Make sure that the baud rates for receiving and transmitting are set to be consistent when using SCU.

##### 1. Communication through RS232

RS232 communication mode is mainly used for short-distance point-to-point communication. The communication distance shall be less than 15m. If SCU communicates with MC through RS232, just connect SCU RS232 port to the RS232 port of MC.

##### 2. Communication through MODEM or ES-MOD

When SCU communicates with MC through MODEM or ES-MOD, it uses PSTN to realize long-distance monitoring. Power supply cables and communication cables shall be prepared for the communication through MODEM.

### 3. Dry Contacts Output

SCU has 8 dry-contact outputs. Every dry-contact output has NC (normally closed) and NO (normally-open) contacts. Every dry-contact output shall be configured before the alarm event occurs. Different dry-contact output can trigger different alarms. Once the alarm event occurs, the dry-contact will close or open to generate the alarm.

If the user has other intelligent equipment to be monitored by SCU, the user can connect the dry contacts to the interface of the intelligent equipment, and control the intelligent equipment through these dry contacts.

Capacity of dry contacts: 2A@30Vdc; 05A@125Vac;

Maximum power dissipation: 60W

### **Functions fulfilled by SCU and MC**

In RS232 and MODEM communication modes, the MC can fulfill the following functions through SCU:

1. Remote acquisition of analog and digital values: MC can acquire the real-time analog and digital values of DC Power System through SCU;
2. Remote control functions: MC can shut down the rectifiers, change the boost charge status to float charge status (or in reverse), silence the alarm and stop/start the battery test through SCU.

### **Alarm category settings for dry contact output**

1. Through setting the parameter of "Relate Relay", the user can configure the alarm category for every dry-contact output. Every dry-contact output has been configured to correspond to an alarm category before SCU is delivered to customer.
2. SCU has PLC functions in the alarm management. The PLC is to realize simple logic operation, i.e. the "And", "Or" and "Not" operations. The PLC inputs are all the possible alarm signals, and the PLC outputs can be used to select one of the 8 dry contacts. The alarm categories can be configured flexibly for every dry-contact output through MC. The PLC settings for every dry-contact have three alarm inputs, and two relation flag. The SN of three alarm categories and the mutual logic relationships need to be configured.

PLC can be set to "Disabled". If PLC functions and alarm co-relation are enabled at the same time, the dry contact will act to activate an alarm when any alarm event occurs.

### Password protection for important operations

The users must input the correct password before they conduct “Maintenance” and “Settings” operations. The password has 3 levels: user, operator or administrator. The authorities of the 3 levels are the same while conducting “Maintenance”, but different in conducting “Settings”. The operator can see 3 more pages than the user, which are “resetting system”, “resetting password” and “modifying system type”. The administrator can see 2 more pages than the operator, which are “modifying password of all levels” and “controlling alarm sound volume”. In addition, the administrator can browse the rectifier parameter serial No., software version and the setting of internal switches. See the following table:

*Table 1-4 Authority and default password*

Level	Authority	Default password
User	Configuration of general parameters	123456
Operator	User's authority, plus resetting system, resetting password and modifying system type.	654321
Administrator	Operator's authority, plus modifying password of all levels, controlling alarm sound volume, browsing system parameters that can be set only through the host	640275

### 1.5.4 Multi-Function Unit (MFU)

#### Outline and components

The outline and the components of the MFU are illustrated in the following figure.

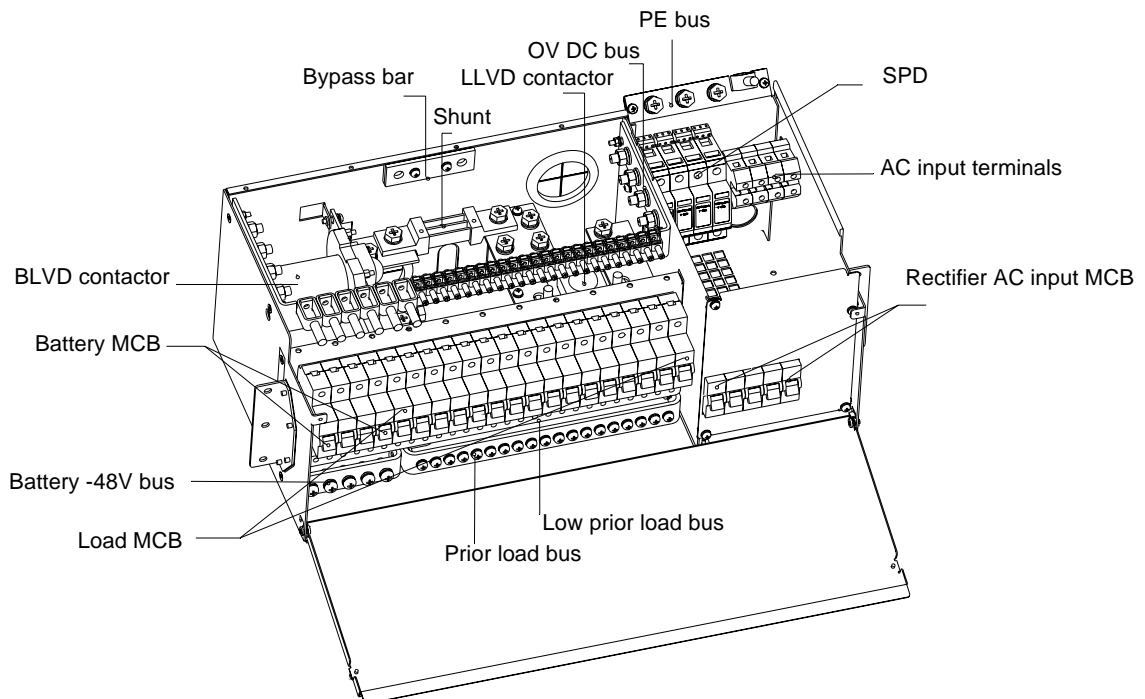

*Figure 1-6 Outline and components of MFU*

Table 1-5 Configuration of MFU

No.	Component	Description
1	SPD	Norminal Dischage Current(8/20 $\mu$ S) 20kA; Ue=385V
2	AC input terminals	Rating Current 150A
3	Rectifier AC input MCB	Rating Current 25A
4	BLVD contactor	200A or 400A optional
5	LLVD contactor	200A or 400A optional
6	Shunt	300A/75mV
7	Battery MCB	100A MCB (up to 5 battery MCBs can be selected to configure)
8	Load MCB	Selected according to user's requirement

The user can mount the distribution unit into cabinets with widths of 600mm and depths of 400mm and 600mm. It has a height of 4.5U (200mm).

### 1.5.5 Battery Connection Unit (BCU)

#### Outline

The outline of the Battery Connection Unit (BCU) is illustrated in Figure1-7.

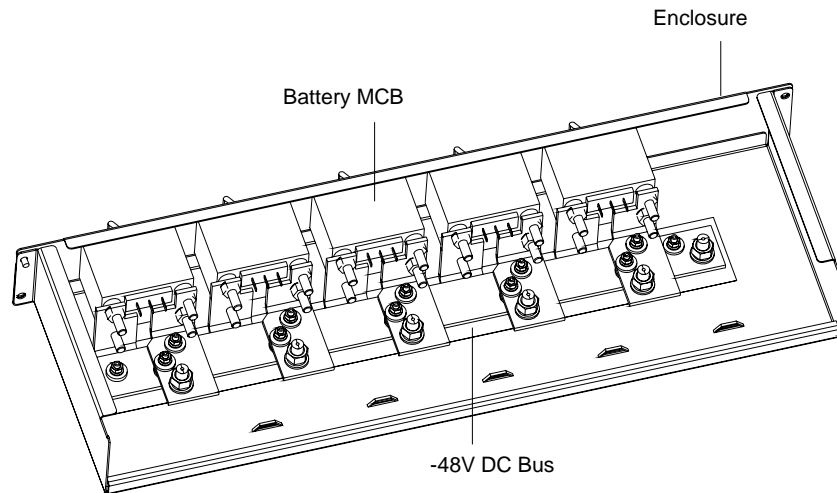

Figure 1-7 Outline of battery connection unit (BCU)

#### Physical size

Battery Connection Unit (BCU) can be installed in cabinets with widths of 600mm and depths of 400mm and 600mm. BCU has a maximum height of 1.5U (67mm).

BCU contains 2 to 5 circuit breakers, each with ratings of 100A and 200A.

#### Alarm output

The BCU will generate an alarm if a battery circuit breaker is off. This alarm shall be possible to connect to the connector board for display in the Controller. It shall be possible to combine the alarms from 2 BCUs to generate a single alarm in the controller. It shall also be possible to combine the alarm from the BCU with an

alarm generated from battery circuit breakers that are switched off in the BCU (for example when using a BCU in an extension battery cabinet and battery circuit breakers in the BCU in a main cabinet).

### BCU configuration

The BCU configuration is as shown in Table 1-6:

*Table 1-6 BCU configuration*

Item	Function unit	Amount
Battery connection unit	100A CB for battery input	2/3/4/5
	200A CB for battery input	2/3/4/5

## 1.5.6 System Cabinet

There are three kinds of cabinets. Their dimensions are 2.0m % 0.6m % 0.6m, 2.0m % 0.6m % 0.4m and 0.7m % 0.6m % 0.4m respectively.

### 2.0m % 0.6m % 0.6m cabinet

This cabinet is installed with 1 % MFU, 1 % Rectifier Sub-rack, 1 % BCU and the following combination of units:

- 16 Blocks of Telion 12V 165Ah FT batteries or 16 % Hawker 12V 155Ah FT batteries
- 20 Blocks of Hawker 12V 105Ah FT batteries
- 16 Blocks of Telion 12V 100Ah FT batteries (20 blocks is preferred, if possible)
- 16 Blocks of Hawker 12V 105Ah Ft batteries and 6U of unspecified equipment (such as DC/DC converters or similar)

### 2.0m % 0.6m % 0.4m cabinet

This cabinet accommodates 1 % MFU, 1 % Rectifier Sub-rack, 1 % BCU and the following combination of units:

- 16 Blocks of Hawker 12V82F batteries or 16 Blocks of Hawker SBSC11 and 3U available for additional equipment such as DC/DC converters
- 20 Blocks of EB4 batteries

20 blocks of Hawker 12V82F batteries (20 blocks and BCU is preferred, if possible)

### 0.7m % 0.6m % 0.4m cabinet

This cabinet accommodates 1 % MFU, 1 % Rectifier Sub-racks and 1 % BCU. There shall be 3U available for the mounting of additional equipment such as DC/DC converters. The cabinet should not be installed any battery.

## Chapter 2 Installation

### 2.1 Installation Preparation

#### 2.1.1 Environmental Conditions

Make sure the following environmental conditions are satisfied when selecting the installation site:

*Table 2-1 Environmental conditions in power room*

Environmental conditions	Recommended range
Ambient temperature	-5~50°C (If ambient temperature > 45°C, for the cabinet with 400mm depth, it should demount the front door of cabinet to ensure the normal operation of the system.)
Humidity	≤90%RH, non-condensing
Dust	≤1mg/m <sup>3</sup>
Sunlight	No direct sunlight
Corrosives	No pollutants, such as salt, acid, and smoke, etc.
Shake	≤1.5m/s <sup>2</sup>
Insects, pests, and termites	None
Mildew	None
Moisture	Water proof
Fire protection	No flammable on the top/bottom of the cabinet.

The DC Power system will be damaged if dust or sand accumulates in it. The following measures are recommended for dusty environment:

- 1.The system should be installed in an airtight and air-conditioned power room. The air-conditioner filter should be well serviced without being obstructed. To reduce the dust in the power room, un-attendance in the power room is recommended.
- 2.The air filter should be cleaned periodically.
- 3.The product should be installed on a cement ground.

#### 2.1.2 Power Supply

AC power supply for communication uses AC mains as its main power source. Backup batteries and generator should be configured according to the actual power supply situation. The AC power supply system composed of AC mains and generator should adopt centralized power supply mode to supply power, while low

voltage AC power supply system should adopt three-phase five-line or single-phase three-line modes.

The AC power cable should adopt copper core cable, and the cable section should suit the load. It is recommended that the power cable outside the power room be buried directly under the ground or by means of cable pipe. Power cable should be wired separately from signal line.

The AC mains voltage shall be within the range of the voltage input range of rectifiers.

The DC power system has a circuit breaker that can cut the AC mains power to it.

### 2.1.3 Site Survey

The power room must be surveyed prior to installation, which should be focused on:

1. Checking the wiring device, including cable chute, wiring rack, floor, wiring holes.
2. Checking the environmental conditions, including temperature, humidity, dust.
3. Checking the conditions for implementing the installation, including power supply and lighting.

### 2.1.4 Tools & Material

1. Tools required for power equipment installation include electric drill, wire cutter, wire presser, various wrenches, screwdriver, electrician knife, and steel saw. The tools must be insulated and antistatic handled before they are used.
2. Power cables for electrical connection include AC cables, DC load cables, battery cables, earth cables, earth bar and lighting connection cables. Their design specifications should be in accordance with relevant specifications in the electrical industry and the materials should be purchased according to the design material list.

AC cables: this system uses 3-phase or single-phase AC power. Copper-core flame-retardant PVC insulated cable and PVC sleeve soft cable, such as NH-BVR, are recommended for the AC cables, whose sectional area should suit the load. When the wiring distance is less than 30 meters, take  $2.5\text{A}/\text{mm}^2$  of economical current density to calculate the sectional area of the AC cables.

The sectional area of the DC load cables and battery cables should be calculated using the following formula:

$$A = \sum I \times L / K \Delta U$$

In this formula:  $A$  is the sectional area of the lead ( $\text{mm}^2$ ),  $\Sigma I$  is the total current (A) flowing through the lead,  $L$  is the length (m) of the lead loop,  $\Delta U$  is the permitted voltage drop on the lead, while  $K$  is the conductivity.  $K_{\text{copper}}=57$ . For safety, the voltage drop on the cables connecting battery and load cannot exceed 3.2V.

The sectional area of the lightning protection earth cable should not be less than  $6\text{mm}^2$ , and that of the DC operation earth cable, usually between  $35\text{-}50\text{mm}^2$ , is determined by user. Take the greatest sectional area among the above 3 earth cables as that of the cable connecting the user earth bar.

3. Purchase materials according to the materials list and inspect the materials, for example, check the heat durability, moisture resistance, flame resistance, and voltage resistance of the cable.
4. The auxiliary materials for power supply installation include expansive bolts, binding strips, and insulating tape.

### 2.1.5 Unpacking

To ensure smooth installation, the power equipment must be carefully inspected when it is unpacked.

The equipment unpacking and inspection are allowed only after it arrives the installation site. The inspection is co-accomplished by the user representative and representative from Emerson Network Power Co., Ltd.

When inspecting the equipment, first open the packing case with packing list put in it, take out the packing list, and conduct inspection against the packing label, including the customer name, customer address, machine No., total amount, case No., contract No., etc.

Unpacking and inspection: after opening the packing case, check the goods one by one according to the goods list on the packing label. The checking should include:

1. The number and serial number marked on the packing cases according to the actual number of the packing cases.
2. The correctness of the equipment packing according to the packing list.
3. The number and model of the accessories according to the accessory list.
4. The completeness of the equipment set according to the system configuration.
5. The condition of the goods through visual inspection. For example, check if the cabinet is damaged, if the cabinet has regained moisture; shake gently the rectifiers and monitoring module to see if the parts and connections have been loosened during delivery.



## 2.2 Installation Procedures

### 2.2.1 Cabinet Installation

#### Installation on the floor

Step 1: mark the position where the power system is to be installed.

Determine the installation position of the power supply cabinet in the power room according to the installation chart. Based on the mechanical specifications (see Fig. 2-1) of the installation holes of the power supply cabinet, determine the accurate position of the center points of the installation holes on the floor, and mark them with a pencil or oil pen.

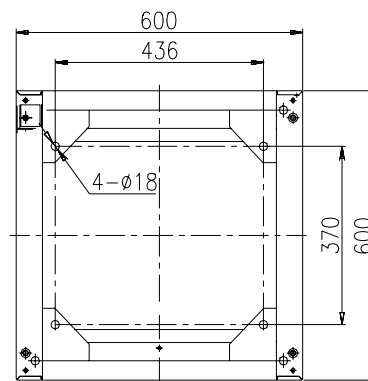

(Applicable to the cabinet with 600mm depth)

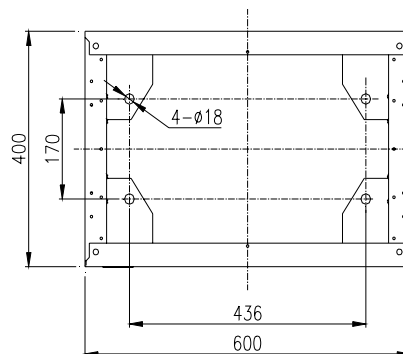

(Applicable to the cabinet with 600mm depth)

Figure 2-1 Installation dimensions of the cabinet base

Step 2: drill reserve holes.

The expansive pipes delivered with the power system are M10%55mm, therefore, use electric drill with drill bit  $\Phi 12$  and depth 70mm to drill holes at the center points of the installation holes marked on the ground. To avoid being off-center, be careful

not to shake the drill, and try to keep as vertical as possible to the ground, as shown in Figure 2-2.

Step 3: install expansive pipes.

Clean the dust, and insert the expansive pipe into the reserve hole, knock it down gently using a hammer until the top of the expansive pipe is level with the ground, as shown in Figure 2-2.

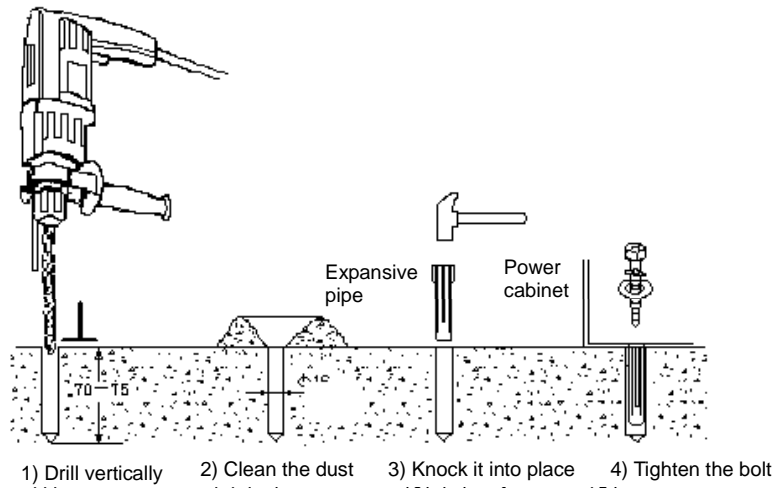

Figure 2-2 Installing expansive pipe

Step 4: place cabinet in position

Move the cabinet to the installation position aligning the installation holes of the cabinet to the expansive pipe on the ground.

Step 5: fix the cabinet

After the cabinet is in position, make some horizontal and vertical adjustments. Insert some iron pieces under the lower edge and corner of the cabinet to adjust the vertical obliquity of the cabinet within 5 degrees. Finally, screw down the tap bolt with plain washer and spring washer into the expansive pipe, and tighten it with wrench. The cabinet fixation is illustrated in Figure 2-3.

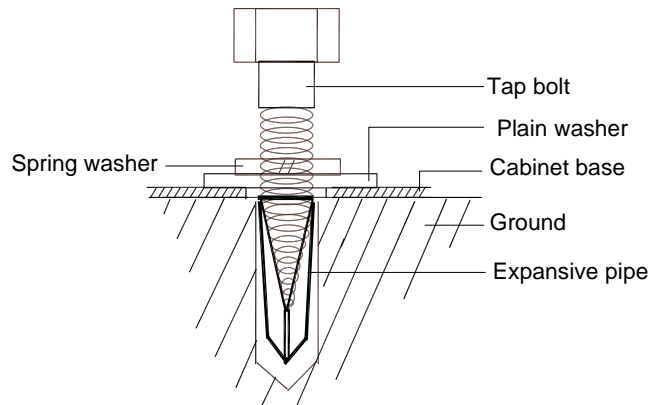

Figure 2-3 Fixing cabinet with Tap

## 2.3 External Electrical Connection Interface

### 2.3.1 Connection Of Input Cables

The AC input terminals, SPD, rectifier AC input switch, PE bus and PE terminals are illustrated in Figure 1-6. SPD is just adjacent to the AC input terminals and has been connected in before delivery. PE bus is at the top of the MFU and is connected to the DC Power Cabinet through screws. PE bus is connected PE terminal through a cable.

#### Connection requirements

The AC mains is connected to the AC input terminals directly. There are 6 AC input modes as shown in Table 2-2:

Table 2-2 AC input modes

Item	Function unit	Amount
AC distribution	3P+N/380V AC input	
	1P+N /220V AC input	
	L1+L2/220V AC input	
	3P/220V AC input	
	Terminals only - for individual rectifier AC feeds	
	2P MCB only - for individual rectifier AC feeds	

#### Connection method

Strip the insulation layer of one end of the AC input cable, and then mounted the cable end with an H terminal.

The cable mounted with an H terminal is shown in Figure 2-4.

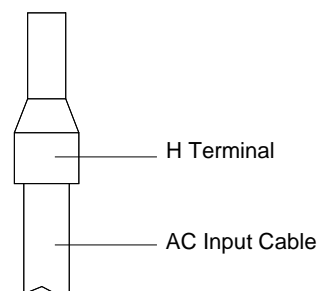

Figure 2-4 Cable mounted with H terminal

After attaching the H terminal to the AC input cable, connect the AC input cable to the AC input terminals as shown in Figure 2-5:

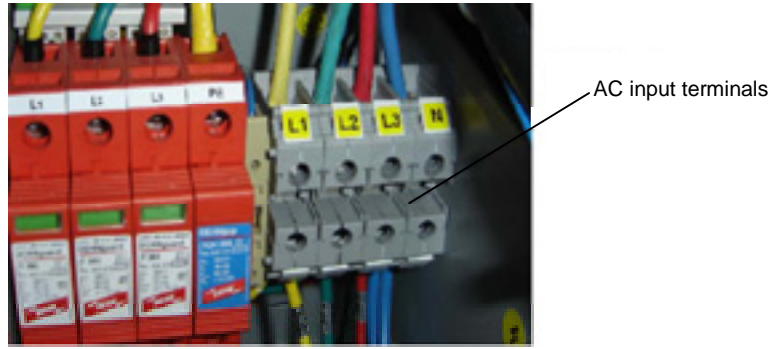

Figure 2-5 Connection of input terminals

The AC input cable is fed to the system through the top cover of the cabinet, as shown in Figure 2-6:

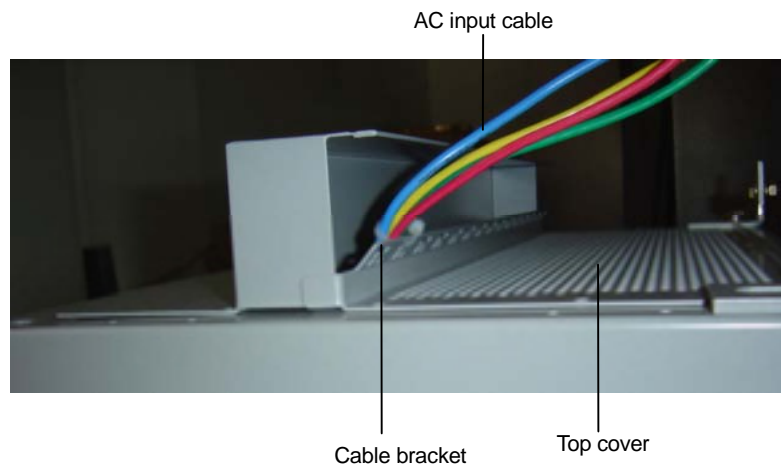

Figure 2-6 Top cover

There is a cable bracket on the top cover. The input cables are bound to the cable bracket with a cable tie.

**Different cable connection modes**

There are 4 AC input terminals. For 3-phase AC power input, just connect the AC input cables as shown in Figure 2-7:

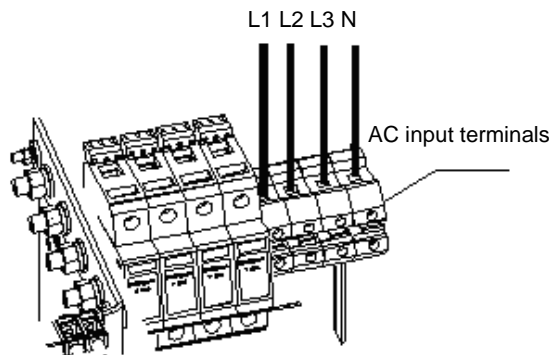

Figure 2-7 Connection of 3-phase AC power input

For single-phase AC power input, connect the AC input cables as in Figure 2-8:

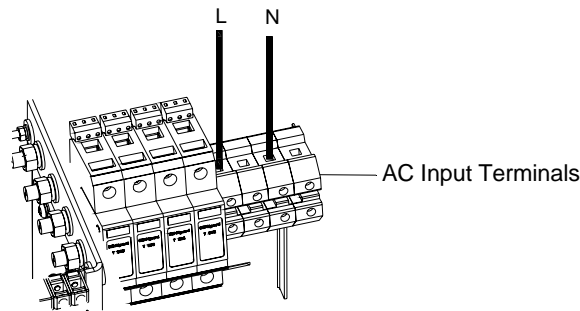

Figure 2-8 Connection of single-phase AC power input

If the AC input is single phase, the second and fourth terminals are not connected.

For dual-phase AC power input, connect the AC input cables as in Figure 2-9:

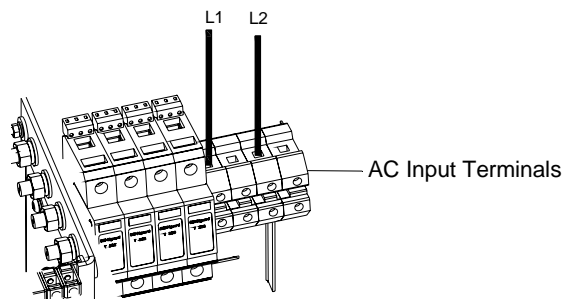

Figure 2-9 Connection of dual-phase AC power input

If the AC input is dual-phase, the second and fourth terminals are not connected.

The yellow, green, red, and light blue AC cables correspond respectively to the AC phase L1, L2, L3 and neutral lines. If the cables are the same color, they should be identified with labels.

The AC cables should be laid separately from the DC cables.

No splice, damage, or scratch on the cables is permitted.

The rectifier AC input cables have already been connected in factory.

#### Note

1. To insure AC input cable has enough bearing current capability, the section area of the AC input cable for 3-phase AC power input should not be less than  $10\text{mm}^2$ ; and for single-phase AC power input and dual-phase AC power, it should not be less than  $25\text{mm}^2$ . The section area of input earth line should not be less than  $35\text{mm}^2$ .

2. The external AC input MCB of cabinet must be sure to disconnect all the AC input lines (including live lines, zero line), but input earth line can not be disconnected by any breaking device. It is recommended that the rated current of the AC input MCB is not less than 125A.

### 2.3.2 Connection Of Load Cables

Loads are connected to the MCB with suitable capacity to avoid their failure to function in the case of overload. The capacity of the MCBs is recommended to be about 1.5 times of the peak value of the load capacity. The load circuit breakers are shown in Figure 1-7. The circuit breakers can be ABB or CBI circuit breakers.

We take the CBI circuit breakers of 13mm for example to illustrate the load cable connection, as shown in the Figure 2-10.

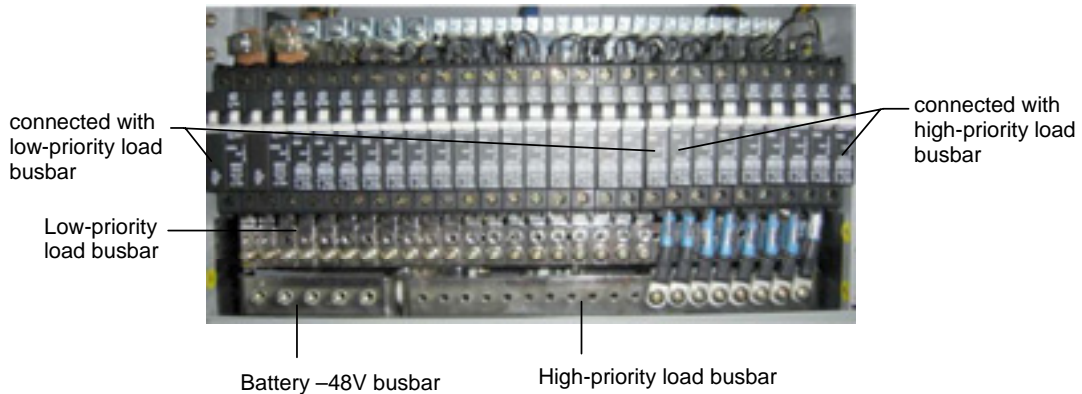

Figure 2-10 Connection of load cables

Explanation: the load MCBs and battery MCBs can be configured flexible according to the actual requirements. Their setting range is shown in the following table.

Table 2-3 Configuration number of load MCBs and battery MCBs

Busbar type	Max. load number	Note
Battery -48V busbar	0~5	Total number of the load should not exceed 20 with 18mm-width MCB or not exceed 28 with 13mm-width MCB.
High-priority load busbar	0~19	
Low-priority load busbar	0~28	

Cable connection to MCB: strip the power cable end, crimp-connect the copper core to an H terminal, See Figure 2-4 for the cable mounted with a H terminal. After attaching the H terminal to the cable, insert the cable into the wiring hole of the MCB, then tighten the screw to fix the copper core, as shown in Figure 2-11:

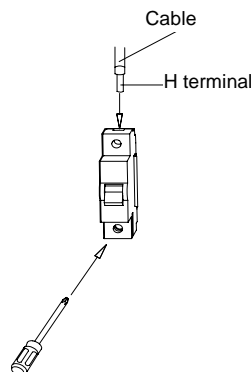

Figure 2-11 Cable connection to MCB

---

**Note**

1. The cable should not be spliced. The load cable, signal cable and AC cables should be wired separately as possible to avoid them affecting each other.
  2. If the power supply system is in operation, switch off the DC output MCB before connecting the cables.
  3. The rated current of the output cable should be bigger than that of the corresponding MCB connected with it.
- 

DC output branch should match the load capacity. It is highly recommended to connect priority load to BLVD branch, and normal load to LLVD branch.

### 2.3.3 Connection Of Communication Cables

There is a connector board in the rectifier shelf. The board is shown in Figure 2-12:

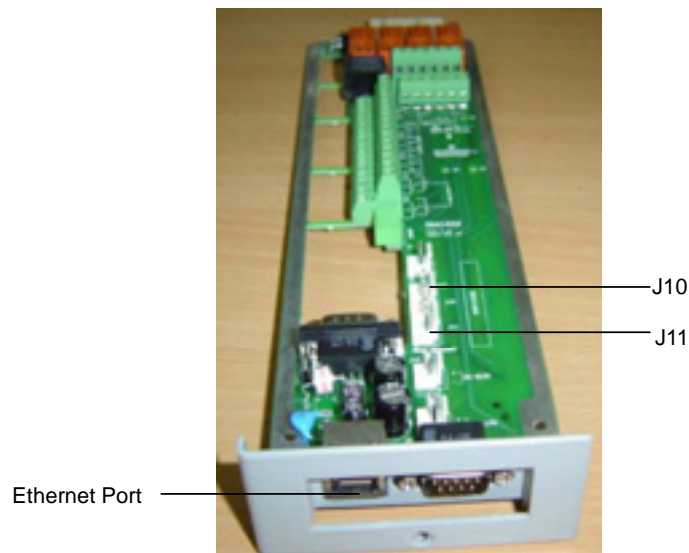

*Figure 2-12 Connector board in rectifier shelf*

There is an Ethernet port and a DB9 RS232 port on the front panel. For the connection of communication cables, first connect the Ethernet port to the transmission equipment, and then connect the DB9 RS232 port to the Main Computer.

### 2.3.4 Layout Of Connector Board S6415X2

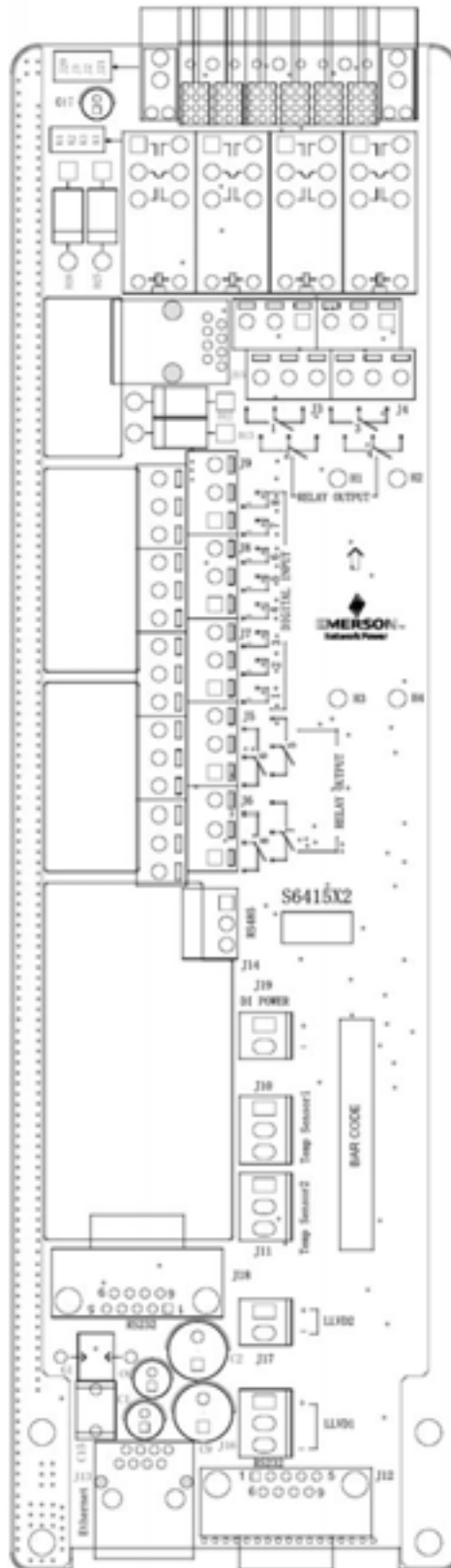

Figure 2-13 Layout of connector board S6415X2



## 2.3.5 Interface Definition Of Connector Board S6415X2

Table 2-4 Interface definition of connector board S6415X2

Connector	Pin	Signal name	Mark number	Logic relation
J3	1	Relay output 1 normal close	DO1_NC	
	2	Relay output 2 normal close	DO2_NC	
	3	Relay output 1 common	DO1_COM	
	4	Relay output 2 common	DO2_COM	
	5	Relay output 1 normal open	DO1_NO	
	6	Relay output 2 normal open	DO2_NO	
J4	1	Relay output 3 normal close	DO3_NC	
	2	Relay output 4 normal close	DO4_NC	
	3	Relay output 3 common	DO3_COM	
	4	Relay output 4 common	DO4_COM	
	5	Relay output 3 normal open	DO3_NO	
	6	Relay output 4 normal open	DO4_NO	
J5	1	Relay output 5 normal close	DO5_NC	
	2	Relay output 6 normal close	DO6_NC	
	3	Relay output 5 common	DO5_COM	
	4	Relay output 6 common	DO6_COM	
	5	Relay output 5 normal open	DO5_NO	
	6	Relay output 6 normal open	DO6_NO	
J6	1	Relay output 7 normal close	DO7_NC	
	2	Relay output 8 normal close	DO8_NC	
	3	Relay output 7 common	DO7_COM	
	4	Relay output 8 common	DO8_COM	
	5	Relay output 7 normal open	DO7_NO	
	6	Relay output 8 normal open	DO8_NO	
J10	1	Digital circuits power	+5V	
	2	Temperature signal 1 input	TEMP1	4~20mA
	3	Analog ground	GND	
J11	1	Digital circuits power	+5V	
	2	Temperature signal 2 input	TEMP2	4~20mA
	3	Analog ground	GND	
J12, J18	1	Data Carrier Detect	DCD232	
	2	Receive Data	RXD232	
	3	Transmit Data	TXD232	
	4	Data Terminal Ready	DTR232	
	5	Data Communication ground	DGND	
	6		Empty	
	7	Request To Send	RTS232	
	8,9		Empty	
J13	1	Ethernet TX+	NETTX+	
	2	Ethernet TX-	NETTX-	
	3	Ethernet TR+	NETTR+	
	4		Empty	
	5		Empty	
	6	Ethernet TR-	NETTR-	
	7~12		Empty	

Connector	Pin	Signal name	Mark number	Logic relation
J14	1	RS485 communication+	E485+	
	2	RS485 communication-	E485-	
	3	Protection ground	PGNG	
J19	1	48V+	POWER+	
	2	48V-	POWER-	

### 2.3.6 Connection Of Temperature Sensor Cables

There are two 3-pin terminals on the connector board in rectifier shelf. These two terminals are J11 and J10 respectively. They are used to connect the temperature sensors. The locations of J11 and J10 are as shown in Figure 2-12.

The user can connect the temperature sensor cables to J11 and J10.

### 2.3.7 Connection With MODEM

Take e-TEK TD-5648DC MODEM for example to illustrate the connection.

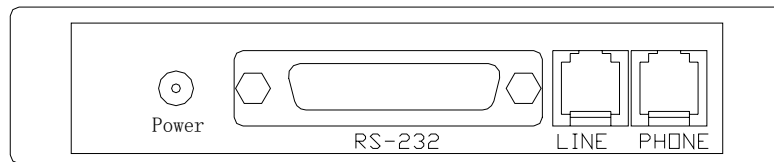

Figure 2-14 Input/output interfaces of TD-5648DC MODEM

#### Connecting modem with M500D control unit

MODEM connects with M500D monitoring module through connector board S6415X2:

1. Connect telephone line to the “LINE” port of MODEM.
2. Connect the 48V “POWER” terminal of MODEM with the J19 socket of connector board S6415X2.
3. Connect “RS-232” (DB25 female) communication port of MODEM with the J12 or J18 terminal (DB9 male) of connector board S6415X2 using a communication cable.

 **Note**

When the cabinet has a front door, before connecting the RS232 terminal, pull out the S6415X2 board first, pass the RS232 terminal through the opening on the right side of the rectifier subrack and connect it with the J18 terminal on the S6415X2 board, then insert the S6415X2 board.

### 2.3.8 Connection With Dry Contacts

The M500D monitoring module provides 8 sets of alarm dry contacts through the J3-J6 sockets on the connector board S6415X2. Each set has a normally open contact and a normally closed contact. Once the corresponding alarm event occurs, the dry contact will act to report alarms under the control of M500D monitoring module. Through the dry contact networking, the system can realize the level isolation transmission of fault signals.

When delivery, each set of dry contacts is corresponding to one default alarm type, and users can reset it as other alarm types.

#### **Connecting method**

After peeling the signal cable terminal, insert it into the dry contact terminal, then tighten the hold-down bolt to compress the signal cable.

## 2.4 Battery Installation And Cabling

### 2.4.1 Battery Installation

The DC Power System with standard configuration has 4 battery strings. The DC Power System with non-standard configuration can connect to up to 5 battery strings. In the system cabinet, there are 5 levels and each battery string is installed in one level. One battery string has four +12V battery blocks.

Procedures to install battery:

1. Install the batteries in the cabinet from low level to high level;
2. Place the battery on the level and push it inward until the battery is blocked;
3. Connect the positive and negative battery cable to the battery string.

The cabinet with four battery strings installed is shown in Figure 2-15:

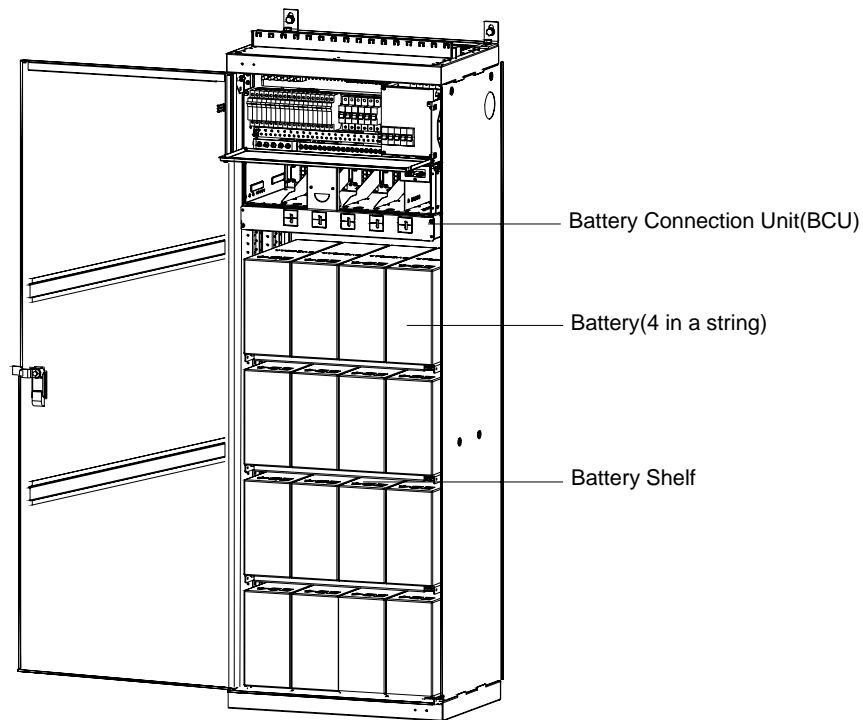

Figure 2-15 Cabinet with four battery strings installed

 **Note**

To satisfy the safety requirement of the whole equipment, the fire-retardant class of the battery materials should not be lower than V-2.

Insure that the charge/discharge current of single battery group is not bigger than 100A, and the total charge/discharge current of the all battery groups are not bigger than 200A.

## 2.4.2 Battery Cable Connection

The battery connection for the cabinet with standard configuration is different from that of the cabinet with non-standard configuration.

### Standard configuration

The DC Power System with standard configuration has no BCU. The system has four battery strings. The negative battery cable is of blue color and the positive one is of black color. There are two connection methods, one is for the cabinet of 600 % 400 % 700(mm), and another is for the cabinets of 600 % 400 % 2000(mm) and 600 % 600 % 2000(mm).

#### 1) Batter Connection for Cabinet of 600 % 400 % 700(mm)

The four left-most circuit breakers in the MFU connect to the negative battery cables (blue) respectively as shown in Figure 2-16. Another end of the negative

battery cable is connected to the negative terminals of the battery string in each level as shown in Figure 2-16:

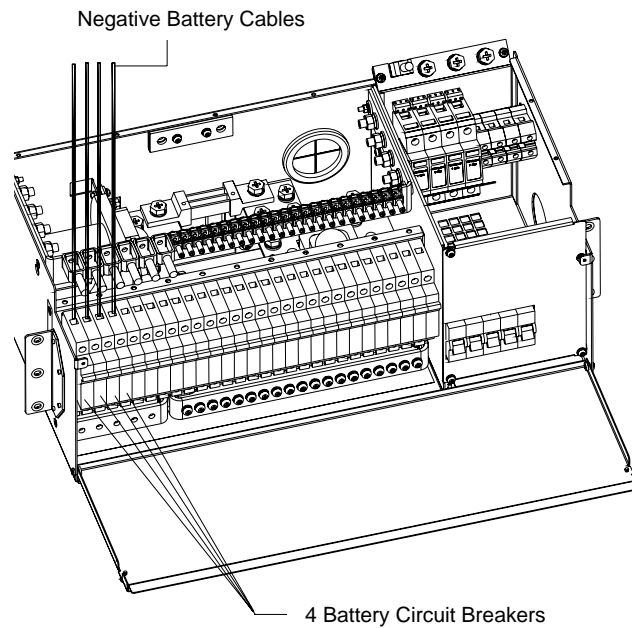

Figure 2-16 Connection of battery cables.

2) Batter Connection for Cabinets of 600 % 400 % 2000(mm) and 600 % 600 % 2000(mm)

The connection is show in Figure 2-17:



Figure 2-17 Positive and negative battery cables in each level

One end of positive battery cable is connected to the neutral bus of the DC power cabinet. Another end of the positive battery cable is connected to the positive terminal of the battery string in each level as shown in Figure 2-17.

---

**Note**

The actual number of battery circuit breakers in MFU may be 0~5 according to the user's need.

---

**Non-standard configuration**

The DC power system with non-standard configuration has a BCU. The connection of positive cables is the same with that of the system with standard configuration. The only difference is that there are five positive battery cables because the system has five battery strings. One end of positive battery cable is connected to the neutral bus of the DC power cabinet. Another end of the positive battery cable is connected to the positive terminal of the battery string in each level as shown in Figure 2-17.

One end of negative battery cable is connected to the negative terminal of the battery string in each level as shown in Figure 2-17. Another end is connected to the BCU as shown in Figure 2-18. The connection has already been done in factory.

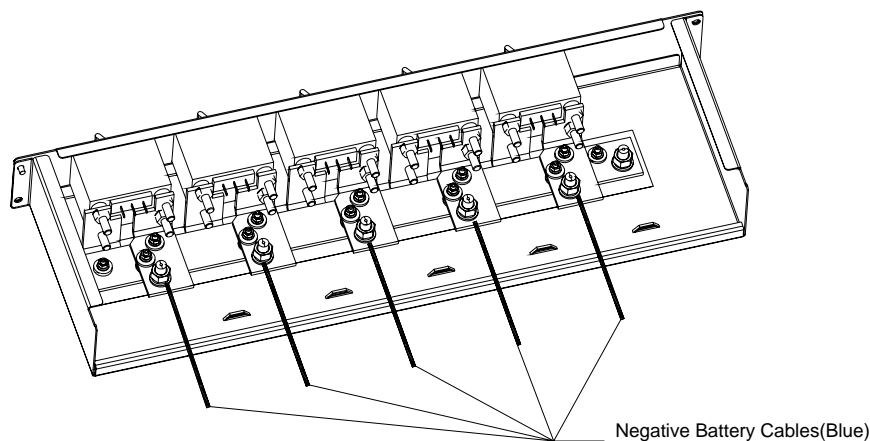

*Figure 2-18 Negative battery cables connection in BCU*

---

**Note**

1. Before connecting the battery cables, the corresponding battery fuse or the battery switch must be disconnected.
  2. Be careful not to reverse connect the battery, otherwise, the battery and the power supply system will be damaged!
- 

Since the battery voltage decreases in discharge, hence the sectional area of the cable connecting the battery and the MFU or BCU should be relatively big to keep the voltage drop on the cable within 0.5V.

## 2.5 Parallel Connection Of Cabinets

In order to prolong the backup time of battery, the battery capacity should be increased. Another cabinet can be connected in parallel with the DC power system cabinet. The expanded cabinet has no rectifier shelf and Multi-Function Unit. It is only installed with battery strings and a BCU. So, it is actually the battery cabinet. BCU in Extension Unit connects to Main Unit through cables. The parallel connection of the DC power system cabinet with the battery cabinet is shown in Figure 2-19:

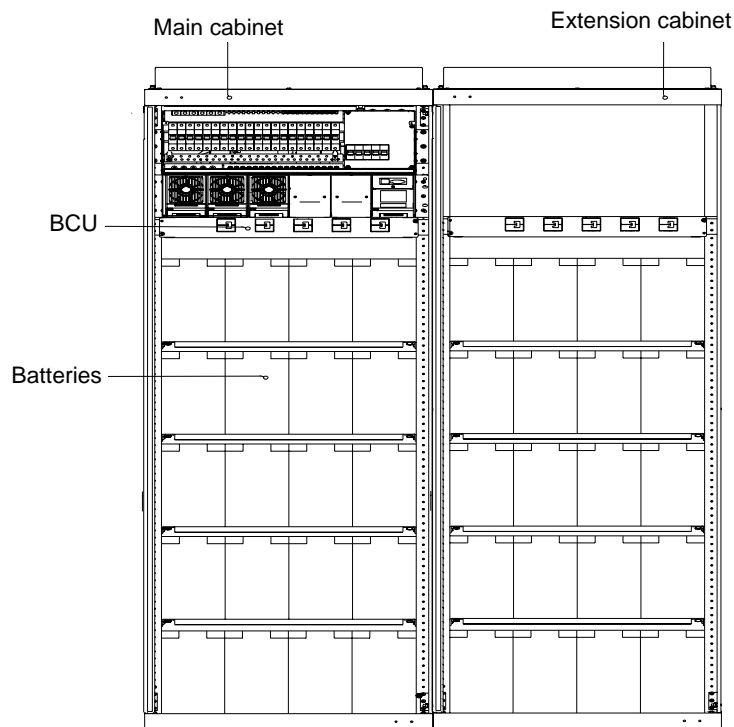

Figure 2-19 Parallel connection of DC power system cabinet with battery cabinet

### DC/Parallel connections

The DC cables are connected to the output of the rectifier shelf in the MFU.

Up to two Battery Connection Units (BCUs) can be connected in the DC Power System – up to one BCU in the main cabinet and up to one BCU in an extension battery cabinet.

SCU can display the alarm signals from these two BCUs.

The user can connect the MFU to an additional extension MFU (only for additional load circuit breakers) through suitably rated cables.

## Chapter 3 Startup

### 3.1 Checking Before Startup

Check the DC Power System according to Table 3-1 before startup.

*Table 3-1 System checklist before startup*

Item	Action	Result	Comments (fill in "Ok" or not)
1	Check all the circuit breakers of the shelf and BCU	They should be switched off.	
2	Check the mains supply fuses/circuit breakers.	They should be removed/switched off.	
3	Check with an ohmmeter between the positive and negative terminals of battery.	They must be no short circuit (>50ohms)	
4	Check with an ohmmeter between the battery terminals and shelf chassis.	They must be no short circuit (>50ohms)	
5	Check the battery block voltage and total battery voltage.	The voltages shall correspond to the values given by battery manufacturer.	
6	Check the mains phase voltage.	The voltage shall be within the rectifier input voltage range (85Vac~290Vac).	
7	Check the connection of cables.	The cables shall be connected to their correct terminals firmly.	



## 3.2 Startup Process

Item	Action	Result	Comments (Fill in "OK" or not)
1	Connect/switch on the mains supply fuses/circuit breakers of the DC shelf.	The LEDs on the rectifiers and the controller will emit light.	
		The rectifier fans will start.	
		The LVD contactors will operate.	
		The green LEDs of the rectifiers and the controller will flash for about 10 s. and then emit steady light.	
2	Check the DC voltage on the test outlet marked U in the supervision unit.	The voltage should be close to what has been set in the controller. If temperature compensated charging is activated, the difference may be $\pm 3$ V from the set value.	
3	If temperature compensated charging is activated, warn the sensor on the battery with your hand and observe the system voltage.	The voltage should start to drop.	
4	Switch on the battery circuit breakers.	The battery voltage will increase and reach the system voltage. (Might take hours, depending on the charging state of the battery.)	
5	Switch on the circuit breakers in MFU.	The loads will get DC supply.	
6	Check all the LEDs of the shelf.	Only the green LEDs are On should emit light. No LED shall flash.	

## 3.3 Parameters Configuration

After start up the DC Power System, following parameters need to be configured:

Password, AC parameters, DC parameters, rectifier parameters, battery parameters, time and communication parameters.

Refer to Chapter 5 on how to configure the parameters.

## Chapter 4 Testing

### 4.1 Testing MFU

Measure the L-N voltage at the input terminals with a multi-meter to check if it is normal.

### 4.2 Testing Rectifier

1. Turn on one rectifier input MCB in the MFU to feed AC supply to the corresponding rectifier, the rectifier should operate normally;
2. Turn off this MCB, and turn on the other rectifier input MCBs one by one to check if all the other rectifiers operate normally.

If all of the rectifiers can operate normally, switch them on. In case of rectifier malfunction, take the rectifier out and inspect it.

### 4.3 Testing SCU

When the rectifiers are operating normally, switch on the SCU, the SCU should start and display the start screen. If the system self-test is normal, seconds later, SCU displays Initial Screen with System Information:

2004-09-16	
53.5V	300 A
System: Alarm	
Auto /BC	▼

There are default system parameter settings in the SCU, including the AC voltage alarm points, DC voltage alarm points, battery management parameters, which are available on the parameter card delivered with the system. If the battery capacity or charging parameters set by user are different from those on the parameter card, or if user has different BLVD management requirements, please reset the system parameters according to the actual situation, and record the new settings on the parameter card.

## 4.4 Battery Breaker Test

1. Before turning on the battery circuit breaker, confirm with a multi-meter that the battery is not reverse-connected.
2. When connecting the battery, be careful not to short the two battery terminals.
3. When connecting two batteries, be careful to avoid battery mutual charging due to unequal terminal voltages of the two batteries.

## 4.5 BCU Test

The BCU can connect to a single battery via suitably sized cables from the Distribution Unit.

The BCU can connect to up to five battery strings via suitably sized cables.

The user can route the battery cables via the left hand side and via the right hand side of the BCU. A maximum of 7 cables can be routed via the left hand side of the BCU and a maximum of 5 cables via the right hand side of the BCU.

The user can mount the BCU 15mm or more above a Front terminal battery. Care shall be taken to connect the battery to the BCU via cables in this orientation.

The user can safely connect battery cables on a live system with only front access. BCU can be partially slid out in order for this to be achieved.

The user can safely install or replace a battery circuit breaker on a live system with only front access. BCU can be partially slid out in order for this to be achieved.

## 4.6 Load Breaker Test

Before connecting load to the system, check with a multi-meter if the connection polarity of the load and the power system is correct and the voltage is normal.

1. Close the load MCB, DC power should be fed to the load;
2. Adjust the system parameters through the SCU, and make sure that the information viewing and output control functions are normal.

## Chapter 5 Operating SCU

### 5.1 Operation Panel

SCU has a LCD with backlight, keys, LEDs and a latch, as shown in Figure 5-1:

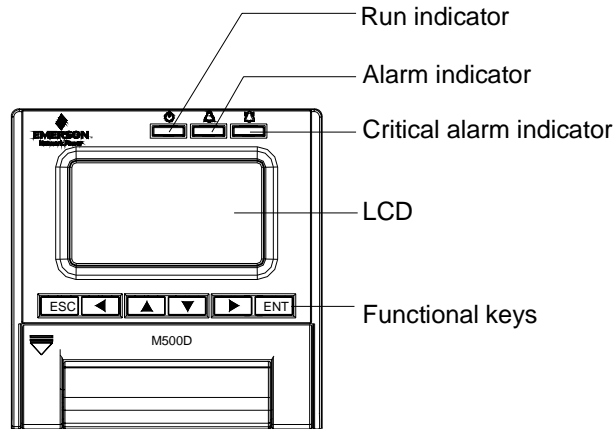

Figure 5-1 SCU Front Panel

Functions of LED indicators are illustrated in Table 5-1

Table 5-1 Functions of LED indicators

Indicator	Normal state	Fault state	Fault cause
RUN (Green)	On	Off	No operation power supply
Alarm (Yellow)	Off	On	There are observation alarms
Critical alarm (Red)	Off	On	There are major or critical alarms

SCU controller uses a 128x64 dot-matrix LCD unit. It has 6 functional keys. Its interface is easy-to-use and supports multi-language display. The panel of the controller is easy-to-remove. The functions of these 6 keys are shown in Table 5-2:

Table 5-2 Functions of SCU keys

Key	Function	
ESC	Return to the upper level menu.	Pressing ESC and ENT simultaneously can reset the monitoring module
ENT	Enter the main menu or confirm the menu operation	
“▲” and “▼”	Shift among parallel menus or parameters.	To change a character string whose digits needs setting separately, use “◀” and “▶” to move the cursor left or right, or “▲” and “▼” to set each digit.
“◀” and “▶”	Change values at a value setting interface. At the first page of system information, use these two keys to change LCD contrast.	

## 5.2 Operation Procedures

After the system is powered on for the first time, you should set the system type according to the actual configuration. The monitoring module will restart after the system type is changed. In that case, you should re-configure those parameters whose default values are inconsistent with the actual situation. Only after that can the monitoring module operate normally.

After configuring the system parameters, you can carry out various operations directly without resetting the parameter values. As for those important parameters related to battery management, such as BLVD, you should be fully aware of their influence upon the system before you change their values.

---

### Note

For the exact meanings of the abbreviations used in LCD displayer, see *Appendix E Glossary*.

---

1. The LCD will prompt you to select a language once the monitoring module is powered on.

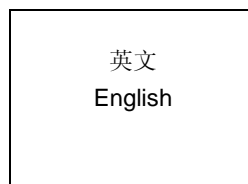

You can use “◀”, “▶”, “▲” or “▼” to select the language you want, and press “ENT” to confirm.

2. The monitoring module will prompt you to wait, and start initialization.

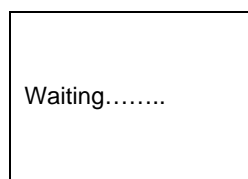

3. The first system information page appears

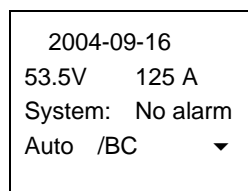

The system information is shown in many pages. You can repeatedly press “▼” to view other system information pages in a cycle.

4. At any system information page, press “ENT” to enter the “MAIN MENU” page, which contains 3 sub-menus: “Status”, “Maintenance” and “Settings”.

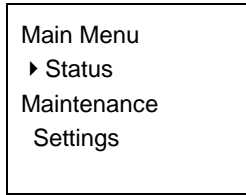

You can press “▲” or “▼” repeatedly to select a sub-menu, and press “ENT” to enter the sub-menu. Press “ESC” to return to the menu of higher level.

#### 1) Status

Including rectifier information, active alarm information and alarm history information.

#### 2) Maintenance

The maintenance operation can be conducted only when the battery management mode is set to “Manual”. The maintenance includes battery FC, BC and test, load power off/on, battery power off/on and rectifier voltage trimming, current limit, switch control and resetting.

#### 3) Settings

Including the setting of alarm parameter, battery parameter, AC/DC parameter, rectifier parameter and system parameter.

## 5.3 Querying System Status

### 5.3.1 First Page Of System Information

1. At the main menu page, press “ESC” to return to the first system information page.

2. If no operation is conducted on the monitoring module keypad for 8 minutes, the LCD will return to the first system information page and shut down the backlight to protect the screen. Pressing any key will turn on the back light.

The first system information page contains the major system operation information, including date/time, busbar voltage, total load current, system operation state (normal or alarm), battery management mode (AUTO or MANUAL) and battery state.

Among which, the battery state include FC, temperature compensation, BC, Cyclic Boost, test, short test and scheduled test. The current time are displayed in two pages shifting at the interval of 2s. One page shows year, month and date, the

other shows hour, minute and second. The year is displayed with 4 digits; other time units are in 2 digits.

10:09:16
53.5V 125 A
System: No alarm
Auto /BC ▼

2004-09-16
53.5V 125 A
System: No alarm
Auto /BC ▼

---

 **Note**

1. At this page, you may use “◀” and “▶” to adjust the LCD contrast (7-level).
  2. If there has been no keypad operation for 8 minutes, the monitoring module will return to the first system information page. The time of that return will be recorded automatically, and can be queried through the host.
- 

### 5.3.2 Other System Information Screen

The system information is shown in many pages. The default page of the monitoring module after the system power on is the system information first page. You can press “▲” or “▼” to scroll up or down to view more operation information, as shown in the following page:

#### Battery information page

Batt1: 295 A
Actual: 99.1%
Batt2: 0 A
Remain: 0% ▼

1. Battery 1, battery 2

They represent respectively the current of the battery that battery shunt 1 and shunt 2 is connected to. If the “Shunt Coeff” of a certain battery group is set to “No”, this situation will be reflected at the battery information page by “Not connected”, and no actual capacity will be displayed.

---

 **Note**

There is only one current shunt in the system, that is “shunt 1”.

---

## 2. Actual battery capacity

The monitoring module can approximately calculate the remaining battery capacity in real time. Through configuration at the host, the remaining battery capacity can be displayed in the mode of percentage, remaining Ah or remaining time, etc. The default is the percentage.

During the normal BC/FC management, the monitoring module regards the rated capacity as the capacity that each battery group can reach. When the battery discharges, the monitoring module will calculate the battery remaining capacity according to the discharge current, discharge time and the preset “battery discharge curve”. When the battery is being charged, the monitoring module will calculate the real-time battery capacity according to the detected charge current, charge time and preset “battery charge efficiency”. If the calculated battery remaining capacity is higher than the rated capacity, the monitoring module will automatically change the calculated battery remaining capacity to the rated capacity.

### AC information page

There is no AC data acquisition board in ACTURA Flex 48330 Power System, so the configuration of “AC Input” can only be set to “None”.

### BC prompt and temperature information page

System Power:	23%
Cyc BC After:	55h ▼

Bat. Temp:	25°C
Amb. Temp:	5°C ▼

If the monitoring module bans BC and no temperature sensor is configured, this page will not be displayed.

The first line of the information page displays the BC prompts, which will be different with different systems, including:

1. Prompt the time of next Cyclic Boost according to the battery state
2. If BC is going on, the “Charging” will be prompted
3. If BC is disabled, this row will be empty



The 2<sup>nd</sup> and 3<sup>rd</sup> rows of the page are the temperature information detected by the temperature sensor. The display will vary with different parameter settings (see 4.7 for parameter setting). If the temperature sensor is not connected or is faulty, system will prompt invalid. Meanwhile, the 4<sup>th</sup> row will display “Check Temp Sensor”.

## 5.4 Querying Rectifier Status

The rectifier information includes the rectifier serial No., voltage, current, current limit, mains situation, rectifier power limit and temperature power limit.

1. At any page of the system information, press “ENT” to enter the main menu.
2. Use “▲” or “▼” keys to select the “Status” sub-menu in the main menu, and press “ENT” to confirm.

```

Status
▶ Rectifiers
  Active Alarm
  Alarm History
  
```

3. Use “▲” or “▼” to select the “Rect Info” submenu, as shown in the above figure. Press “ENT” to confirm.

```

Rect 1: 01234567
      54.1V 30.2A
      AC On DC on
      AC Volt: 220V
  
```

```

Rect 1: 01234567
CurrLimit: 34%
AC Derated: Y
Temp Derated: N
  
```

The information of every rectifier is displayed in two pages. The information in the first page includes: rectifier serial No., output voltage and current, AC/DC on/off state and AC input voltage. The information in the second page includes: rectifier serial No., current limit, the states of “AC Derated” and “Temp Derated”. Press “▶” to scroll to the next page, or “◀” to return to the last.

4. Press “▼” or “▲” to query other rectifier’s information.

At most 48 pieces of rectifier’s information can be displayed. If the rectifier does not exist, there will be no information. If the rectifier communication is interrupted, the information will be displayed in high light.

5. At any rectifier information page, press “ESC” repeatedly and you can return to the higher-level menus.

## 5.5 Querying Alarms And Setting Alarm Plans

The monitoring module can locate and record the system fault according to the collected data, as well as raise audible/visual alarms and output through dry contact according to the preset alarm level. Meanwhile, it reports the alarms to the host.

You can query historical alarms and active alarms through the LCD of the monitoring module.

### 5.5.1 Querying Active Alarm

When a new alarm is raised, and there is no operation on monitoring module keypad within 2 minutes, the LCD of the monitoring module will prompt automatically the active alarm.

If there are multiple alarms in the current system, you can query alarms through the following steps:

1. At any system information page, press “ENT” to enter the main menu
2. Use “▲” or “▼” to select the “Status” submenu in the main menu and press “ENT” to confirm.

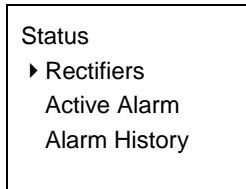

3. Press “▲” or “▼” to select the “Active Alarm”, as shown in the above figure, and press “ENT” to confirm.

- 1) If there is no active alarm, “Active Alarm: None” will be displayed

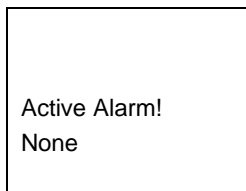

2) If there is any alarm, the display will be like the following:

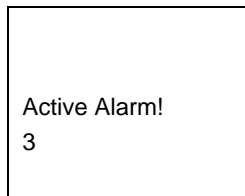

```
Active Alarm!  
3
```

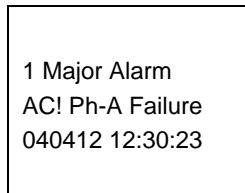

```
1 Major Alarm  
AC! Ph-A Failure  
040412 12:30:23
```

The information in the active alarm information pages includes: alarm serial No., alarm level, alarm name and time (year, month, day, hour, minute and second). The alarm raising time determines the sequence it is displayed, with the latest alarm displayed first. Use “▲” or “▼” to view all active alarms.

While querying rectifier alarms, press “▶”, and the rectifier ID will be displayed, and the “Run” indicator of the corresponding rectifier will blink.

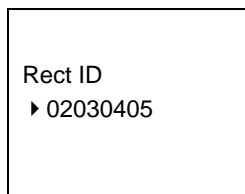

```
Rect ID  
▶ 02030405
```

In the case of battery test alarm or maintenance time alarm, press “▶” to display the prompt information.

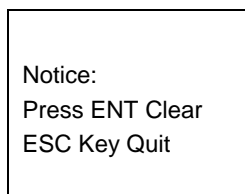

```
Notice:  
Press ENT Clear  
ESC Key Quit
```

In the prompt page, press “ENT” to confirm the alarm.

4. At any active alarm information page, press “ESC” repeatedly and you can return to the higher-level menus.

### 5.5.2 Query Alarm History

1. At any system information page, press “ENT” to enter the main menu
2. Press “▲” or “▼” to select the “Status” submenu, and press “ENT” to confirm.

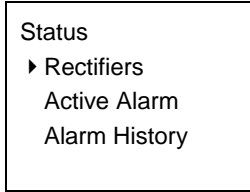

3. Use “▲” or “▼” to select the “Alarm History”, as shown in the above figure and press “ENT” to confirm.

If there is no historical alarm, the prompt will be “Alarm History: None”.

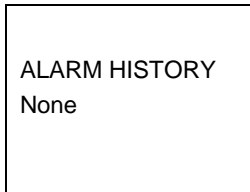

The historical alarms of the monitoring module are stored in cyclic order. Up to 200 alarms will be recorded. Above that, the earliest alarm will be cleared automatically.

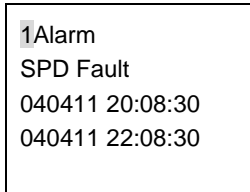

At the monitoring module, the displayed historical alarm information includes: alarm serial No., alarm name and alarm start/end time (year, month, day, hour, minute, second).

If it is a rectifier that raised the alarm, the ID of that rectifier will be displayed.

4. At any Alarm History information page, press “ESC” repeatedly to return to the higher-level menus.

## 5.5.3 Alarm Type Table

Table 5-3 Alarm type table

Serial No.	Alarm	Description	Default alarm level	Default related relay	Related parameter configuration
1	Input MCB Trip	The system AC input MCB tripped	Critical	None	Only in a system with AC sampling board
2	SPD Fault	The SPD circuit is faulty	Critical	8	
3	Digit Input Fault	The alarm name is user defined, not longer than 10 characters. The high/low level alarm can be set in the alarm mode.	No alarm	None	In a system with AC sampling board, you can name 2 routes; in a system without AC sampling, you can name 8 routes
4	DC/DC Failure	Including DC/DC converter fault	Critical	None	
5	AC Over Volt	The system AC input voltage is higher than the set value of parameter "OverVolt"	Critical	None	Over-voltage alarm
6	Ph-X Volt Low	The system AC input voltage is lower than the set value of parameter "LowVolt"	Critical	None	Under-voltage alarm
7	Phase failure	The AC input voltage of the power system is lower than 80V	Critical	None	
8	Power Failure	In double-AC auto-switchover system: 1. All AC voltage inputs are lower than 80V. 2. Both AC inputs 1 and 2 are broken. In single AC input system or double-AC manual-switchover system, the AC voltage of all rectifiers are lower than 80V	Major	1	
9	DC Voltage High	System DC output voltage is higher than the set value of parameter "Temp Threshold: Over"	Critical	2	Over-voltage alarm
10	DC Under-volt	System DC output voltage is lower than the set value of parameter "Temp Threshold: Under"	Critical	2	Under-voltage alarm
11	DC Voltage Low	System DC output voltage is lower than the set value of parameter "Temp Threshold: Low"	Observation	2	Low-voltage alarm
12	Batt Overtemp	Battery temperature is higher than the set value of parameter "Temp Threshold: Over Temp"	Major	None	Over-temperature alarm point
13	Batt Temp High	Battery temperature is higher than the set value of parameter "Temp Threshold: High Temp"	Observation	None	High temperature alarm point

Serial No.	Alarm	Description	Default alarm level	Default related relay	Related parameter configuration
14	Batt Temp Low	Battery temperature is lower than the set value of parameter "Temp Threshold: Low Temp"	Observation	None	Low temperature alarm point
15	Amb Temp High	Ambient temperature is higher than the set alarm point	Observation	None	
16	Amb Temp Low	Ambient temperature is lower than the alarm point	Observation	None	
17	No TempSensor1	Temperature sensor 1 has been set, but no sensor is actually connected	Critical	None	
18	No TempSensor2	Temperature sensor 2 has been set, but no sensor is actually connected	Critical	None	
19	TempSensor1 Err	Temperature sensor 1 detected unreasonable temperature	Critical	None	
20	TempSensor2 Err	Temperature sensor 2 detected unreasonable temperature	Critical	None	
21	LLVD	1. Load disconnection 2. Manual load disconnection	Critical	5	LLVD enabled
22	BLVD	1. When battery discharges till its voltage is lower than the "BLVD Volt", or the discharge time is longer than the "BLVD Time", the BLVD contactor will be open automatically 2. BLVD through manual operation	Critical	4	BLVD enabled
23	Load 1 Faivre	Over-load, short circuit, manual disconnection or alarm circuit faulty	Critical	6	
24	Load 2 Faivre	Over-load, short circuit, manual disconnection or alarm circuit faulty	Critical	6	
25	Load 3 Faivre	Over-load, short circuit, manual disconnection or alarm circuit faulty	Critical	6	
26	Load 4 Faivre	Over-load, short circuit, manual disconnection or alarm circuit faulty	Critical	6	
27	Load 5 Faivre	Over-load, short circuit, manual disconnection or alarm circuit faulty	Critical	6	
28	Load 6 Faivre	Over-load, short circuit, manual disconnection or alarm circuit faulty	Critical	6	
29	Load 7 Faivre	Over-load, short circuit, manual disconnection or alarm circuit faulty	Critical	6	
30	Load 8 Faivre	Over-load, short circuit, manual disconnection or alarm circuit faulty	Critical	6	
31	Load 9 Faivre	Over-load, short circuit, manual disconnection or alarm circuit faulty	Critical	6	
32	Aux Load Fails	The last route faulty	Critical	6	
33	Batt1 Failure	Over-load, short circuit, manual disconnection or alarm circuit faulty	Critical	None	
34	Batt2 Failure	Over-load, short circuit, manual disconnection or alarm circuit faulty	Critical	None	
35	Batt3 Failure	Over-load, short circuit, manual disconnection or alarm circuit faulty	Critical	None	

Serial No.	Alarm	Description	Default alarm level	Default related relay	Related parameter configuration
36	Batt4 Failure	Over-load, short circuit, manual disconnection or alarm circuit faulty	Critical	None	
37	Batt1 Over-curr	The charge current of battery group 1 is bigger than the set value of parameter "Over"	Observation	None	
38	Batt2 Over-curr	The charge current of battery group 2 is bigger than the set value of parameter "Over"	Observation	None	
39	Rect Vac Err	All AC voltages are lower than the AC low-volt point	Major	3	
40	Rect Over Temp	Rectifier internal temperature higher than 90°C	Observation	None	
41	Rect Failure	Rectifier over-voltage, higher than rectifier high threshold	Critical	3	
42	Rect Protect	AC over-voltage ( $\geq 295V$ ) or under-voltage ( $\leq 80V$ )	Observation	3	
43	Rect Fan Fails	Fan faulty	Major	3	
44	Rect PowerLimit	AC voltage lower than 176V, with rectifier internal higher than 85°C or temperature at inlet higher than 45°C	Observation	3	
45	Rect Com Failure	Rectifier and monitoring module communication interrupted	Major	3	
46	Multi Rect Fail	More than 2 rectifiers raised alarms	Critical	None	
47	Self-detect error	Error is detected through hardware self-detection	No alarm	None	
48	Manual Mode	Battery management in the manual state	No alarm	None	
49	Non-FC Status	Including auto-BC, Cyclic Boost, constant current test and short test	No alarm	7	
50	Batt Discharge	Battery being discharging	No alarm	None	
51	Curr Imbalance	In a system with load shunt, the detected load current plus battery current differs sharply from the rectifier output current	No alarm	None	Not existent in this power system series
52	Batt Test Error	Battery discharge time unexpectedly short	Observation	None	
53	Short Test Fault	During the short test, the two batteries discharged more than the set value	Observation	None	
54	Outvolt Fault	The maintenance FC voltage different from the busbar voltage, or the reported data. The difference is more than 1V	Observation	None	
55	System Maintain	The pre-set system maintenance time is due	Observation	None	
56	Alarm Block	Alarms sent to the host are blocked, valid in EEM-M protocol	No alarm	None	

 **Note**

When the DC load 9 and its above (load 10, load 11 ...) have circuit fault alarm, the monitoring module all display “Load 9 Failure” or “Aux Load Fails”.

#### 5.5.4 Changing Audible/Visual Alarm And Alarm Call Back Plan

There are different audible/visual alarms and call back modes for alarms of different levels. For the products in China market, the alarming mode for major alarms and critical alarms are the same.

*Table 5-4 Changing audible/visual alarm and alarm call back plan*

Alarm level	Red indicator	Yellow indicator	Alarm horn	Call back	Remark
Critical	ON	/	ON	Y	Callback No. can be set
Major	ON	/	ON	Y	Callback No. can be set
Observation	/	ON	OFF	N	
No alarm	OFF	OFF	OFF	N	

Therefore, changing the alarm level of different alarms may change their audible/visual alarm mode and call back plan too.

Pressing any key on the monitoring module can silence the alarm sound. The sound will disappear and alarm indicator will be off when all alarms are cleared.

You can configure how long an alarm sound will last, or choose to make no alarm sound. For details, see 5.7.11 *Alarms Settings*.

#### 5.5.5 Changing Alarm Types Of Dry Contacts

As one of the alarm type parameter, “Related Relay” refers to the serial No. of the dry contract corresponding to the alarm type, whose value is either 1 ~ 8 or “None”. “None” means there is no corresponding dry contact. For details, see 4.7.11 *Alarms Settings*.

#### 5.5.6 Setting Alarm Type For Dry Contacts

The Programmable Logic Control (PLC) is configured through the host software.

The way to configure the PLC function is:

$$C = A (\text{Status}) * B (\text{Status})$$

C: The dry contract serial No. of the corresponding output. Range: 1 ~ 8.

A, B: The input alarm type. Status: Whether the alarm has been raised.



\*: The logic relationship between the two alarms. Options: “And”/”Or”.

The optional alarm types are listed in the following table:

*Table 5-5 Optional alarm types*

Alarm type	Remark
Alarm Block	
Load route 1	
Load route 2	
Load route 3	
Load route 4	
Load route 5	
Load route 6	
Load route 7	
Load route 8	
Load route 9	
Auxiliary load route	
SPD faulty	
AC input MCB tripped	Valid in the double AC inputs auto-switchover power system
AC route 1 in operation	
AC route 2 in operation	
DC/DC faulty	
Digit Input (DI) 7	
DI 8	
DC voltage	
Phase A of AC route 1	Valid in the double AC inputs auto-switchover power system
Phase B of AC route 1	
Phase C of AC route 1	
Phase A of AC route 2	
Phase B of AC route 2	
Phase C of AC route 2	
Load current	Valid in the system with load shunt
Battery 1 current	Valid in the system with battery shunt
Battery 2 current	Valid in the system with battery shunt
Fuse of battery 1	
Fuse of battery 2	
Fuse of battery 3	
Fuse of battery 4	
Temperature detection 1	
Temperature detection 2	
Monitoring module in operation	Used for monitoring module power off
Module self test	
Manual mode	
Non-FC state of battery	
Battery discharge	
Current imbalance	
Battery short test	
Battery test alarm	
LLVD	

Alarm type	Remark
BLVD	
Output voltage abnormal	
AC power off	
Multiple rectifiers alarm	
Time for system maintenance (replace the fan)	
Any rectifier comm interrupted	
Any rectifier AC power off	
Any rectifier over-temperature	
Any rctifier faulty	
Any rectifier in protection	
Any rectifier fan faulty	
Any AC derated rectifier	
Any temperature derated rectifier	

For example: To make dry contact No.3 act when battery route 1 is broken but AC power is still on, the PLC should be configured like this:

A: battery route 1, with “status” set as “Alarm”.

B: AC power off, with “status” set as “No alarm”.

C: Dry contact No.3

\*: “AND”.

### 5.5.7 Set the Alarm Names Through PLC Function

Connect the serial port of MC to the RS-232 port of SCU, then configure the alarm types that correspond to the dry contact outputs through MC.

An 8 (row) % 6 (column) logic matrix is used in configuring these 8 dry contacts. Every row in the matrix corresponds to one dry contact. The setting of one dry contact has 6 bytes.

Byte 0: The dry contact is disabled if byte 0 is set to 0, and enabled if byte0 is set to 1.

Bytes 1, 3 and 5 are the SN of the 3 alarms respectively. The range of SN is 0-56, see section “5.5.3 Alarm List” for details.

Bytes 2 and 4 define the logic relationship between 3 alarms. The setting of byte 2 or 4 is 0-3. If the setting is 0, the logic is “AND”; If the setting is “1”, the logic is “NOT”; If the setting is “2”, the logic is “OR”; and if the setting is “3”, the logic is “AND”.

Table 5-6 Logic matrix used for configuring 8 dry contacts

	Setting	0,1	Alarm SN	Logic	Alarm SN	Logic	Alarm SN
	Column(B) Row(A)	0	1	2	3	4	5
Dry Contact 0	0						
Dry Contact 1	1						
Dry Contact 2	2						
Dry Contact 3	3						
Dry Contact 4	4						
Dry Contact 5	5						
Dry Contact 6	6						
Dry Contact 7	7						

The format of PLC setting is AlarmPLC[A][B]=C.

Where, “A” is the row No., and “B” is the column No., and “C” is the value of the matrix element. An example is shown in the following table:

Table 5-7 Example of PLC setting

PLC byte	Byte description	Function
AlarmPLC[3][0]=1	Element value of Row 3 and Column 0 is 1.	Use Dry Contact 3
AlarmPLC[3][1]=1	Element value of Row 3 and Column 1 is 1.	Alarm SN of Fuse 1 Blow up
AlarmPLC[3][2]=3	Element value of Row 3 and Column 2 is 3.	AND Logic
AlarmPLC[3][3]=2	Element value of Row 3 and Column 3 is 2.	Alarm SN of Fuse 2 Blow up
AlarmPLC[3][4]=3	Element value of Row 3 and Column 4 is 3.	OR Logic
AlarmPLC[3][5]=43	Element value of Row 3 and Column 5 is 43.	Alarm SN of LLVD

For the above PLC setting: When alarms of “Fuse 1 Blow up” and “Fuse 2 Blow up” occur at the same time, or LLVD occurs, dry contact 3 will output the alarm signal.

Relationship between PLC SN and Alarm:

Table 5-8 PLC SN and Alarm

PLC SN	Alarm description	Remark
0	Alarm Block	Disabled for China Market, Enabled for rest of world
1	Load 1 Failure	
2	Load 2 Failure	
3	Load 3 Failure	
4	Load 4 Failure	
5	Load 5 Failure	

PLC SN	Alarm description	Remark
6	Load 6 Failure	
7	Load 7 Failure	
8	Load 8 Failure	
9	Load 9 Failure	
10	Aux Load Fails	Load 10 is Auxiliary Load for China Market
11	SPD Fault	Enabled when an AC Signal Acquisition Board is installed.
12	Input MCB Trip	Enabled when an AC Signal Acquisition Board is installed.
13	Flag of Effective AC Input	Flag of Effective AC Input
14	Flag of Effective AC Input	Flag of Effective AC Input
15	DC/DC Failure	Enabled when an AC Signal Acquisition Board is installed.
16	Digital Input 6	
17	Digital Input 7	
18	Digital Input 8	
19	DC Voltage	
20	Phase A of AC 1	Enabled when an AC Signal Acquisition Board is installed.
21	Phase B of AC 1	Enabled when an AC Signal Acquisition Board is installed.
22	Phase C of AC 1	Enabled when an AC Signal Acquisition Board is installed.
23	Phase A of AC 2	Enabled when an AC Signal Acquisition Board is installed.
24	Phase B of AC 2	Enabled when an AC Signal Acquisition Board is installed.
25	Phase C of AC 2	Enabled when an AC Signal Acquisition Board is installed.
26	Load Current	Enabled when a load shunt is connected in DC Power System
27	Batt1 Curr	Enabled when a battery shunt is connected in DC Power System
28	Batt2 Curr	Enabled when a battery shunt is connected in DC Power System
29	Batt1 Fuse	
30	Batt2 Fuse	
31	Batt3 Fuse	
32	Batt4 Fuse	
33	Measured Temp1	
34	Measured Temp2	
35	SCU Working	For LVD
36	Self-detect Error	
37	Manual Mode	
38	Non-FC Status	
39	Batt Discharge	
40	Curr Imbalance	Only for China Market

PLC SN	Alarm description	Remark
41	Short Test Error	
42	BattTest Error	
43	LLVD	
44	BLVD	
45	Outvolt Error	
46	Power Failure	
47	Multi-Rect Fails	Disabled for China Market, Enabled for rest of world
48	Rect Fan Fails	
49	Rect Com Failure	
50	Rect Vac Err	
51	Rect Over Temp	
52	Rect Failure	
53	Rect Protect	
54	Rect Fan Fails	
55	Rect PowerLimit	
56	Derateby Temp	

## 5.6 Maintenance

### Note

1. This operation can be conducted only when the battery management is set to “Manual”.
2. Be careful! BLVD operations may result in power interruption.

#### Operation Procedures:

1. At any information page, press “ENT” to enter the main menu.
2. Press “▼” to select the “Maintenance” menu.

You cannot enter the system Maintenance menu if the “Battery Management” is set to “Auto”.

3. Press “ENT” and input the correct operation password. Press “ENT” again to enter the “Maintenance” menu.

Enter Password:  
123456

To input the password, use “▲” or “▼” to modify numbers, and use “◀” or “▶” to move the cursor. After the input, press “ENT” to confirm.

If the password is incorrect, system will prompt “password incorrect”. If the password is less than 6 digits, end it with a “#”.

---

 **Note**

You can choose to enter the “Maintenance” menu by using either the user, operator or administrator password, for in this menu, all users have the same authority.

---

4. Press “▲” or “▼” to scroll to the operation page you need.

There are two pages:

Maintenance  
 Start : BC  
 Batt: Reconnect  
 Load: Disconnect ▼

RectTrim: 53.5V  
 CurrLimit: 110%  
 Rect 1: DC On  
 ID 01234567 ▼

5. Press “◀” and “▶” to select the needed action.

“Start”: The options include “FC”, “BC” and “Test”. If system is not configured with any battery, the control would be invalid. If there is AC power off alarm, or the busbar voltage is too low, the BC and battery test control will not be executed by the system. No battery test control can be conducted when the rectifier communication is interrupted. Finally, after the battery test, the battery management mode will be changed from “Manual” to “Auto” automatically.

“Battery”: The options include “Reconnect” and “Disconnect”. If there is no battery, or there is a battery alarm, the battery operations will be invalid.

“Load”: The options include “Reconnect” and “Disconnect”.

The following maintenance over the rectifier can be conducted only when the power system is in the FC state.

“RectTrim”: Range: 42V ~ 58V. It can be used to improve the current sharing among rectifiers. Note that the value of this parameter cannot exceed the over-voltage alarm point, or the parameter will be invalid.

“RectLimit”: Range: 10% ~ 121%.

The maintenance operations over a single rectifier include: “DC ON/OFF”, “AC ON/OFF” and “Reset”. The operation method is:

- ① Use “▲” or “▼” to select the rectifier parameter, and “◀” or “▶” to change the rectifier serial No. Then press “ENT” to confirm. The bottom line of the page displays the rectifier ID.
- ② Use “▲” or “▼” to move the cursor to the maintenance operation area, and “◀” or “▶” to select the value.

If the rectifier voltage is too high, you can select “Reset” to restore the output voltage of that rectifier to normal.

6. There will be prompts as the confirmation of control commands. If the maintenance operation is valid, system will prompt you press “ENT” to confirm and execute the operation, or “ESC” to abort the operation. Otherwise, system will prompt you the operation is invalid, and press “ESC” to quit.

Press ENT to Run

Other Key Quit

No Maintain!

ESC Quit

Press “ESC” to return to the menu of higher level.

## 5.7 Setting System Parameters

Battery parameters are very important, for they are related to the life of battery. Before delivery, the battery parameters have been initialized. Without any special needs, you only need to reset the battery group number and battery capacity, and accept the defaults for other parameters.

### 5.7.1 Parameter Setting Method

1. At any system information page, press “ENT” to enter the main menu.

MAIN MENU

▶ status

Maintenance

Settings

2. Use “▲” or “▼” to select the submenu “Settings” and press “ENT” to confirm. System will then prompt you to input the password.

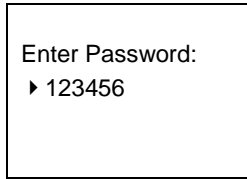

3. Press "◀" or "▶" to select the number of password digits. Enter the password digit by digit using “▲” or “▼”. Press “ENT” to confirm and enter the parameter setting submenu.

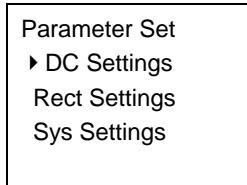
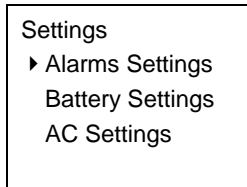

Users with different password levels have different authorities. See the following table:

Table 5-9 Password levels and authorities

Level	Authority	Default password
User	Configuration of general parameters	123456
Operator	User's authority, plus resetting system, resetting password and modifying system type.	654321
Administrator	Operator's authority, plus modifying password of all levels, controlling alarm sound volume, browsing system parameters that can be set only through the host	640275

4. There are two pages of “Settings”. Shift page by using “▼” or “▲”, and select the parameter by using “▼” or “▲”. Press “ENT” to confirm.

As shown in the above figure, the monitoring module divides the parameters to be set into 6 kinds: alarms parameter, battery parameter, AC parameter, DC parameter, rectifier parameter and system parameter.

Among which, the battery parameters are divided into 5 kinds: basic, BLVD, charging management, battery test, temperature coefficient, and they are displayed in two pages, as shown below:



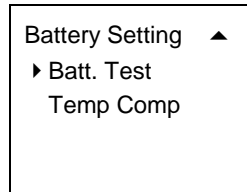
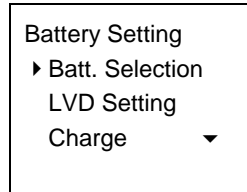

What follows is the description of the parameter functions and values by dividing them into 5 small categories and 5 big categories.

### 5.7.2 Batt. Selection

1. The first page of the Batt. Selection is shown below:

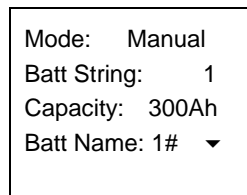

Use “▼” or “▲” to select the page and the parameter to be set, and “◀” or “▶” to select the proper value for the parameter. Press “ENT” to confirm.

After setting the “Battery Type”, the following prompt will appear, asking you to name a certain type of battery for the sake of identifying them:

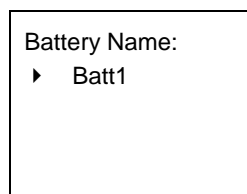

To name a rectifier, you can use “▲” or “▼” to change the number, and “◀” or “▶” to move the cursor left or right. Press “ENT” to confirm afterwards.

2. If setting parameter “System Type” does not require setting the battery shunt coefficient, the second page of the basic battery settings is as follows:

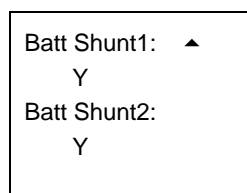

3. If setting parameter “System Type” requires setting the battery shunt coefficient, the second page of the basic battery settings is as follows:

Batt Shunt1: Yes ▲  
 Batt Shunt2: No  
 Shunt Coeff:  
 300A / 75mV

4. The value description of the basic battery parameters is listed below:

*Table 5-10 Value description of the basic battery parameters*

Parameter	Range	Defaults	Value description
Mgmt Mode (Management mode)	Auto, Manual	Auto	In normal situation, it should be in the “Auto” mode, which enables the monitoring module manage the whole power system automatically, including: Automatic FC/BC switchover, LLVD and BLVC. In the manual mode, you can do operations like BC, FC, test and battery on/off, as well as enabling automatic battery BC time protection and capacity calculation. Upon the system DC under-voltage alarm, system can automatically switch to the “Auto” mode, lest wrong manual operation should damage the system
Batt String (number of battery strings)	0 ~ 4	4	You should set this parameter according to the actual battery configuration. If “Batt Shunt” is set as “Y”, there should be batteries actually configured
Rated AH (rated capacity)	50 ~ 5000Ah	300Ah	The capacity of a single battery string. You should set this parameter according to the actual battery configuration.
BTT Name	1# ~ 11#	1#	
Battery Name	10 characters		Name different battery types to identify them
Batt Shunt1	Yes, No	Yes	Select “Y” when a corresponding shunt is configured, otherwise, select “N”. Battery management aims at only the batteries connected to the shunt
Batt Shunt2		No	
Shunt Coeff (shunt coefficient)	Dependent on system type		In the system type setting, if the parameter “Shunt” is set to “Y”, this parameter will be displayed. Otherwise this parameter will take the default value, and is the same for both battery strings.

### 5.7.3 LVD Parameter Description

#### 1. Function description

LLVD means the monitoring module opens the LLVD contactor, so that the non-priority load will be powered off. In this way, the battery remaining capacity can sustain the priority load longer.

BLVD means the monitoring module opens the BLVD contactor. In this way, the battery will stop powering the load, preventing over-discharge.

2. There are 3 related pages, as shown below:

LLVD Enable: Y  
 BLVD Enable: Y  
 LVD Mode:  
 Voltage ▼

LVD Vlotage ▲  
 LLVD: 44.0  
 BLVD: 43.2  
 ▼

LVD Time ▲  
 LLVD: 300min  
 BLVD: 600min  
 ▼

Use “▼” or “▲” to select one page or one of the parameters, and “◀” or “▶” to select the parameter value. Press “ENT” to confirm and save.

 **Note**

Generally you do not need to set the LVD parameters’ value. The defaults will do.

3. The value description of the LVD parameters is listed below.

*Table 5-11 Value description of the LVD parameters*

Parameter	Range	Default	Value description
LLVD Enable	Y, N	Y	Select “Y” to enable LLVD function
BLVD Enable			Select “Y” to disable the BLVD function
LLVD Mode	Time, voltage	Voltage	Select “Voltage”, when the monitoring module detects that the battery voltage is lower than the preset “LLVD Volt”, the load will be disconnected, and so is the battery when the battery voltage is lower than the preset ‘BLVD Volt’.
LLVD Volt	40V ~ 60V	44.0V	
BLVD Volt		43.2V	
LLVD Time	3 ~ 1,000 min	300min	Select “Time”, when the discharge time reaches the preset “LLVD Time”, the monitoring module will disconnect the load; when the discharge time reaches the preset “BLVD Time”, it will disconnect the battery
BLVD Time		600min	

### 5.7.4 Charging Management Parameters

1. There are 6 related pages, as shown below:

Float: 53.5 ▲  
 Boost: 56.4  
 Limit: 0.100C10  
 Over: 0.300c10 ▼

Automatic Boost ▲
Y
Cyclic Boost:
Y ▼

To Boost ▲
Current: 80%
Capacity: 0.06C10
▼

Constant Boost ▲
Current: 0.01C10
Duration: 180min
▼

Cyclic Boost ▲
Interval: 400h
Duration: 300min
▼

Boost Limit ▲
Time: 300min

Use “▼” or “▲” to select one page or one of the parameters, and “◀” or “▶” to select the parameter value. Press “ENT” to confirm and save.

---

 **Note**

Generally you do not need to set the management value. The defaults will do.

---

2. The charging management parameter value description is listed below:

Table 5-12 Charging management parameter value description

Parameter	Range	Default	Value description	
Float	42V ~ 58V	53.5V	In the FC state, all rectifiers output voltage according to the set "Float"	The "Boost" must be higher than the "Float"
Boost		56.4V	In the BC state, all rectifiers output voltage according to the set "Boost"	
Limit (current limit)	0.1 ~ 0.25C <sub>10</sub>	0.1C <sub>10</sub>	When the monitoring module detects that the battery charging current is higher than the "Limit", it will control the current of the rectifiers, through which it can limit the battery charging current. C <sub>10</sub> is the battery rated capacity, generally set to 10 ~ 20% of the rated capacity of one battery string.	
Over (over current point)	0.3C <sub>10</sub> ~ 1.0C <sub>10</sub>	0.300C <sub>10</sub>	When the monitoring module detects that the battery charging current is higher than the "Over", it will raise the battery charge over-current alarm.	
Automatic Boost	Yes, No	Y	Select "Y", and BC will be conducted when conditions allow	
Cyclic Boost			Select "Y", and the monitoring module will control the system to enter the Cyclic Boost when the FC time reaches the "Cyclic Boost Interval". The battery charging voltage is the preset "Boost", and the time is the preset "Cyclic Boost Time"	
Cyclic Boost Interval	48 ~ 8760h	2400h		
Cyclic Boost Time	30 ~ 2880min	720min		
To Boost Current	0.50 ~ 0.80C <sub>10</sub>	0.06C <sub>10</sub>	The monitoring module will control the system enter the BC state when the battery capacity decreases to the value of "To Boost Capacity", or when the charge current reaches the "To Boost Current". The charge voltage will be the "Boost".	
To Boost Capacity	0.1 ~ 0.95	0.80		
Constant BC Curr	0.02 ~ 0.99C <sub>10</sub>	0.01C <sub>10</sub>	The system in the BC state will enter the FC state when the charge current decreases to the "Constant BC Curr" and after the "Duration". The battery charge voltage then will be the "Float".	
Duration (of constant BC)	30 ~ 1440min	180min		
Boost Limit	60 ~ 2880min	1080min	To ensure safety, the monitoring module will forcefully control the system to enter the FC state if during the BC state, the BC time reaches the "Boost Limit", or abnormalities occur (such as AC failure and battery route faulty, etc.).	

3. The BC/FC switchover diagram is shown below:

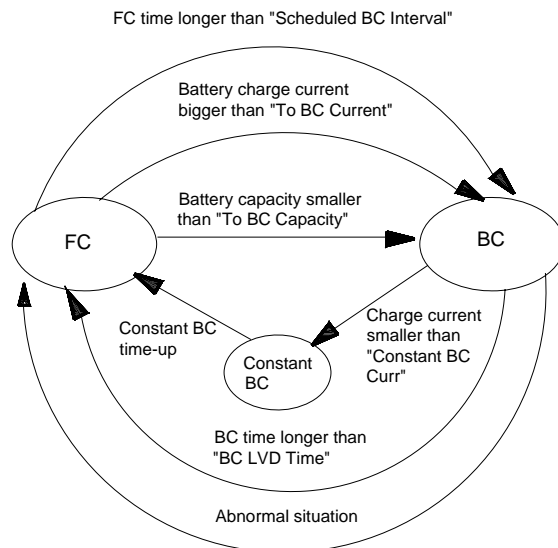

Figure 5-2 BC/FC switchover diagram

### 5.7.5 Battery Test Parameters

1. There are 7 related pages, as shown below:

Battery Test
Voltage: 45.2
Time: 300min
▼

Test End Cap: ▲
0.700C10
Planned Test:
N ▼

Planned Test1:
01.02 12Hr
Planned Test2:
04.02 12Hr

Planned Test3:
07.02 12Hr
Planned Test4:
07.02 12Hr

Short Test: ▲
Enable: Y
Alarm Current
10A ▼

Short Test:
Cycle: 300h
Duration:
5min

Stable Test
Enable: Y
Current:
9999A

Use “▼” or “▲” to select one page or one of the parameters, and “◀” or “▶” to select the parameter value. Press “ENT” to confirm and save.

2. The value description of the parameters is listed below:

Table 5-13 Value description of the battery test parameters

Parameter	Range	Default	Value description
Battery test voltage	43.1V ~ 57.9V	45.2V	The monitoring module can do battery test, and record 10 sets of test data (accessible only through the host). The battery test has to be started manually, then monitoring module will control the rectifier output voltage, make it lower than the battery voltage, and the battery discharge will begin. Monitoring module will stop the test if the battery voltage reaches the "Battery test voltage", or the discharge time reaches "Battery test time", or the battery capacity reaches "Test End Cap". Afterwards, it will restore the rectifier output voltage to the normal FC voltage, begin the battery charge and switch the system to battery auto-management. Meanwhile the test start time/voltage and end time/voltage and battery remaining capacity will be recorded. The records can be queried through the host. During the battery test, if abnormalities occur, the monitoring module will stop the battery test automatically.
Battery test time	5 ~ 1440min	300min	
Test End Cap (capacity)	0.01C <sub>10</sub> ~ 0.95C <sub>10</sub>	0.7C <sub>10</sub>	
Scheduled Test	Y, N	Y	
Planned Test 1	Month, day, hour	00:00, Jan. 1 <sup>st</sup>	When the parameter "Scheduled Test" is set to "Y", the monitoring module will test the battery according to the 4 sets of test time. You can set at most 12 sets of test time through the host.
Planned Test 2		00:00, April 1 <sup>st</sup>	
Planned Test 3		00:00, July 1 <sup>st</sup>	
Planned Test 4		00:00, Oct. 1 <sup>st</sup>	
Alarm Current	1A ~ 100A	10A	If the battery have not discharged within the "ShortTest Cycle", the monitoring module will start a short test, whose operation time is set by the parameter "ShortTest Duration". By the end of the test, if the difference in the discharge currents of batteries is bigger than the "Alarm Current", the battery discharge imbalance alarm will be raised. This alarm will automatically end after 5min of delay. Also you can end it by confirming it.
ShortTest Cycle	24h ~ 8,760h	720h	
ShortTest Duration	1 ~ 60min	5min	
StableTest Enable	Y, N		The stable test is conducted with constant battery current, whose value is set through the parameter "StableTest Current". If the parameter "StableTest Enable" is set to "Y", and the test will be started once the battery satisfies the test condition
StableTest Current	0 ~ 9999A	9999A	

3. The schematic diagram of the test function is shown below:

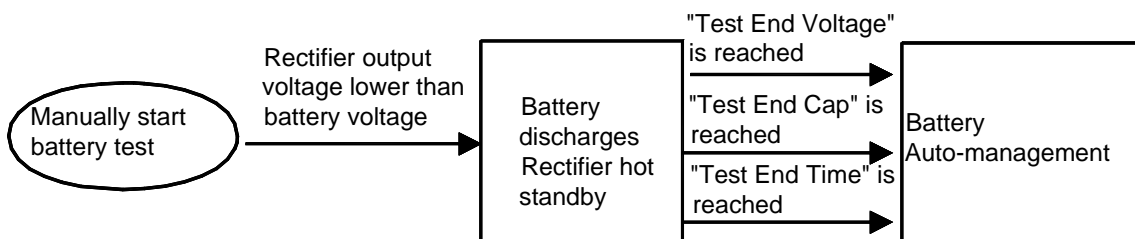

Figure 5-3 Schematic diagram of the test function

### 5.7.6 Temperature Compensation Coefficient Parameters

1. The first page of the setting interface is shown below:

Temp 1:	▲
Ambient	
Temp 2:	
Battery	▼

2. If the “Temperature1” or “Temperature2” is set to “Battery Temp”, you need to set the following parameters:

Center Temp:	▲
25°C	
Temp. Comp:	
70mV / °C /Str	▼

Batt Temp Alarm	▲
Over:	70°C
High:	50°C
Low:	0°C

Use “▼” or “▲” to select one page or one of the parameters, and “◀” or “▶” to select the parameter value. Press “ENT” to confirm and save.

3. The value description of the parameters is listed below:

*Table 5-14 Value description of temperature compensation coefficient*

Parameter	Range		Default	Value description
Temp 1	Ambient Temp, None, Battery Temp		None	The “Ambient Temp” and “Battery Temp” refer to the measurement of the ambient or battery temperature sensor at the local power system. “None” means there is no measurement input. You should set the parameter according to the actual situation. The temperature measurement data will be displayed in the system operation information screen.
Temp 2				
When Temp 1 or Temp 2 is set to “Battery Temp”	Center Temp	10°C ~40°C	25°C	Batteries are sensitive to temperature. To ensure battery’s capacity and life, its FC voltage should change together with the temperature: lower FC voltage for higher temperature, and vice versa. $<FC = \text{BattTemp} - \text{Center Temp} \% \text{Temp Comp}$ Upon alarms such as “Rect Com Failure”, “DC Under-volt” and “DC Voltage High”, the monitoring module will not do temperature compensation to the battery FC voltage. Set this parameter according to the actual battery technical parameters
	Temp Comp	0~500mV/°C	The default is 72mV/°C for 48V system and 36mV/°C for 24V system.	



Parameter	Range		Default	Value description	
When Temp 1 or Temp 2 is set to "Battery Temp"	Over	10 C ~ 100 C	50°C	When the detected battery temperature is higher than the "Over", the monitoring module will raise an alarm	The "High" must not be higher than the "Over"
	High	10°C ~ 100°C	50°C	When the detected battery temperature is higher than the "High", the monitoring module will raise an alarm	
	Low	-40°C ~ 10°C	0°C	The monitoring module will raise an alarm when the detected battery temperature is lower than the "Low"	

### 5.7.7 AC Settings

1. The configuration interface is shown below:

OverVolt:	240V
LowVolt:	210V
UnderVolt:	200V
AC Input:	None

Use "▼" or "▲" to select one page or one of the parameters, and "◀" or "▶" to select the parameter value. Press "ENT" to confirm and save.

2. The value description of the parameters is listed below:

*Table 5-15 Value description of AC settings*

Parameter	Range	Default	Value description	
OverVolt	50V ~ 300V	280V	The monitoring module will raise an alarm when the AC input voltage is higher than the "OverVolt"	The "OverVolt" must be higher than the "LowVolt".
LowVolt	50V ~ 300V	170V	The monitoring module will raise an alarm when the AC input voltage is lower than the "LowVolt".	To avoid alarm disorder, it is suggested to use the default values
UnderVolt	50V ~ 300V	80V	The monitoring module will raise an alarm when the AC voltage of an operating route is lower than the "UnderVolt", but there will be no alarm when the AC voltage of the standby route is lower than the "UnderVolt"	The "UnderVolt" must be lower than the "LowVolt".
AC Input	3-phase, Single Phase, None	Dependat on system type	Set this parameter according to the actual situation. In a system with an AC sampling board, you can only select "Single Phase" or "3-phase"; in a system without an AC sampling board, you can select only "None".	

### 5.7.8 DC Setting

1. There are three related pages, as shown below:

DC Volt Alarm Over: 58.5V Low: 45.0V Under: 45.0V
--

Amb. Temp Alarm ▲ High: 25°C Low: 0°C
---

Load Shunt ▲ None Shunt Coeff: None
--

Use “▼” or “▲” to select one page or one of the parameters, and “◀” or “▶” to select the parameter value. Press “ENT” to confirm and save.

2. The value description of the parameters is listed below:

*Table 5-16 Value description of DC settings*

Parameter	Range	Default	Value description	
Over (over-voltage)	40V ~ 60V	58.5V	The “DC Over Voltage” alarm will be raised when the system DC output voltage is higher than the value of “Over”	The values of these three parameters should be: Over > Low > Under
Low (low-voltage)		45.0V	The DC low voltage alarm will be raised when the system DC output voltage is lower than the value of “Low”	
Under (under-voltage)		45.0V	The DC under voltage alarm will be raised when the system DC output voltage is lower than the value of “Under”	
High (high temperature)	10°C ~ 100°C	40°C	The high temperature alarm will be raised when the detected ambient temperature is higher than the value of “High”	The value of parameter “High” must be higher than that of parameter “Low”
Low (low temperature)	-40°C ~ 10°C	-5°C	The low temperature alarm will be raised when the detected ambient temperature is lower than the value of “Low”	
Load shunt	Y, None	None	Set according to the system actual situation	
Shunt Coeff	Dependent on system type		In the system with a load shunt, this parameter can be set only when the parameter “Shunt” (as a system type) is set to “Set”.	

### 5.7.9 Rect Settings

1. There are three related pages, as shown below:

Rect Over Volt: 59.0V Default Volt: 42.0V ▼
--

Walk-in Enabled ▲ N Walk-in Time: 8s ▼
---

Fan Speed ▲ Full Speed HVSD Time: 300s ▼
---

Use “▼” or “▲” to select one page or one of the parameters, and “◀” or “▶” to select the parameter value. Press “ENT” to confirm and save.

2. The value description of the parameters is listed below:

*Table 5-17 Value description of rectifier settings*

Parameter	Range	Default	Value description	
Rect Over Volt	56V ~ 59V	59V	The rectifier over voltage alarm will be raised when the rectifier output voltage is higher than the “Rect Over Volt”	The “Default Volt” must be lower than the “Rect Over Volt”
Default Volt	48V ~ 58V	53.5V		
Walkin Enabled	Y, N	N	The output soft start function means the rectifier voltage will rise from 0V to the “Default Volt” after the “Walkin Time”	
Walkin Time	8s ~ 128s	10s		
Fan Speed	Full Speed, Half Speed	Half speed	When set to “Half Speed”, the rectifier will regulate the fan speed according to the temperature. When set to “Full Speed”, the fan will operate at full speed	
HVSD Time	50s ~ 300s	300s	The rectifier will shut off automatically upon over-voltage, and restart after a certain delay to see whether it is still over-voltage then. That delay is set through the parameter “HVSD Time”. If the rectifier’s output voltage is normal within the delay, the rectifier is regarded normal; otherwise, the rectifier will be locked out and auto-restart function will be disabled	

### 5.7.10 System Settings

Users of different password levels have different authorities.

1. For the user level password (123456), there are 2 related pages, as shown below:

Adress: 1
Text: Chinese
CommMode:Modem
Baud: 9600

Set Date: ▲
2004-05-01
Set Time:
17:30:30

Use “▼” or “▲” to select one page or one of the parameters, and “◀” or “▶” to select the parameter value. Press “ENT” to confirm and save.

When the “CommMode” is “modem” or “EEM-M”, the “CallBack Number” and “CallBack Num” (how many times should callback be made) should be set.

Call back Num: ▲
5
Call back Set
Code1 ▼

CallBack Number:
▶ 01234567901234
56789

Use “▼” or “▲” to change the number, and “◀” or “▶” to move the cursor left or right. Press “ENT” to confirm.

2. For the operator level password (by default: 654321) or administrator level password (by default: 640275), you can see the following pages, besides the pages above, as shown below:

```
System Type:
48V/50A/300/NONE
Serial No:
2004051025252 ▼
```

There will be a prompt when resetting the system:

```
Notice:
All Param Lost!
ENT Continue
ESC Quit ▼
```

3. For administrator level password (by default: 640275), you can see the following pages, besides all those above, as shown below:

```
Change Password:
Code
Con Alarm Voice:
1 Hour
```

```
Serial:
12345689101112
SW Ver: 1.00
Set Enable: Y
```

You can change the value of “Change Password” and press “ENT” to confirm.

```
Enter New PWD:
▶ 000000

Input Again!
```

Use “▼” or “▲” to change the number, and “◀” or “▶” to move the cursor left or right. Press “ENT” to confirm. You should input the same number twice to complete the setting.

4. The value description of the parameters is listed below:

Table 5-18 Value description of system settings

Parameter		Range	Default	Value description
Text		Chinese, English and Spanish	Chinese	Set according to your need
Address		1 ~ 254		The addresses of power systems that are at the same monitored office should be different
CommMode		modem, EEM-M, RS-232		“MODEM”: Through modem and based on the Telecom protocol. “EEM-M”: Through modem and based on the EES protocol. “RS-232”: Through a transparent serial port and based on the Telecom protocol
BaudRate		1200bps, 2400bps, 4800bps, 9600bps		Make sure the baud rates of both the sending and receiving parties are the same
When “CommMode” is set to “MODEM” or “EEM-M”	CallBack Num.	1 ~ 10	3	Set according to the actual need. In a extension system, sometimes you need to put a “,” between the main number and extension number. When the callback number is less than 19 digits, end it with a “#”
	CallBack Number	19 digits at most		
Set Date		2,000 ~ 2,099		Set the time according to the current actual time, regardless of whether it is a leap year or not
Set Time		Hour, min, sec		
Operator level or above	Initialize password	Y, N	N	Selecting “Y” can reset the user level and administrator level passwords to the defaults
	Init Param (Initialize parameters)	Y, N	N	When the system parameters cannot be set normally, and the usual resetting methods do not work, you can set the “Init Param” to Y, and all the system parameters will be restored to defaults. Alarms may be raised for the defaults may fail to meet the actual situation. Set the parameters according to the actual situation then.

Parameter		Range	Default	Value description
Operator level or above	System Type	24V/75A/500/NONE 24V/75A/500/MAN 24V/75A/500/AUTO 24V/50A/500/NONE 24V/50A/500/MAN 24V/50A/500/AUTO 48V/50A/500/NONE 48V/50A/500/MAN 48V/50A/500/AUTO 48V/50A/300/NONE 48V/50A/300/MAN 48V/50A/300/AUTO 48V/30A/300/NONE 48V/30A/300/MAN 48V/30A/300/AUTO 48V/30A/100/NONE 48V/30A/100/MAN 48V/30A/100/AUTO 48V/15A/100/NONE 48V/15A/100/MAN 48V/15A/100/AUTO 48V/100A/SET/NON 48V/100A/SET/MAN 48V/100A/SET/AUT 48V/50A/SET/NONE 48V/30A/SET/NONE		This parameter has been set according to the actual situation upon delivery and needs not to be changed. However, when a new monitoring module is used, its "System Type" should be set according to the actual situation. After this parameter is changed, the monitoring module will restart automatically, and other parameters of the monitoring module will be changed to the defaults of the corresponding system type. You should change some parameters according to the actual situation.
Administrator	Change Password	User, Operator, Admin		The password can be 6 digits long at most. If it is shorter than 6 digits, end it with a "#"
	Con Alarm Voice	3min, 10min, 1h, 4h, constant	Constant	The period that an alarm sound will last
	Serial	The production serial No. of the monitoring module. This parameter cannot be changed		
	SW Ver	The software version No. of the monitoring module. This parameter cannot be changed		
	Set Enable	Reflecting the jumper status of a hardware switch within the monitoring module. If this parameter is set to "N", you are not allowed to use the jumper, nor change any parameter except the battery management mode. The maintenance over the monitoring module will not be affected		

5. The model description is shown below:

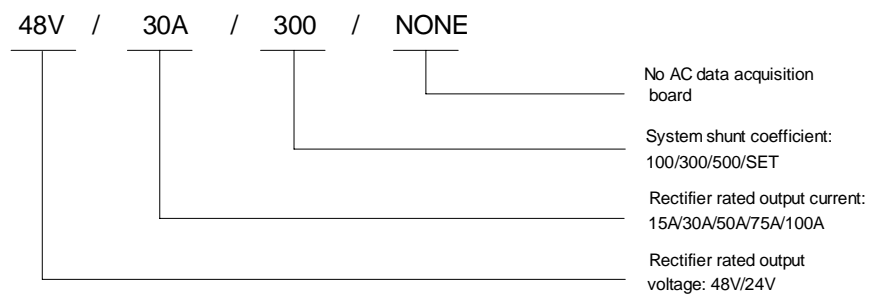

Figure 5-4 System model description

The relationship between the system model and system type is listed in the following table:

*Table 5-19 Relationship between system model and system type*

Power system model	System type
PS48400-3/2900, Single AC Input	48V/50A/300/NONE
PS48400-3/2900, Double AC Inputs, Manual Switchover	48V/50A/300/MAN
PS48400-3/2900, Double AC Inputs, Auto Switchover	48V/50A/300/AUTO
PS48600-3/2900, Single AC Input	48V/50A/500/NONE
PS48600-3/2900, Double AC Inputs, Manual Switchover	48V/50A/500/MAN
PS48600-3/2900, Double AC inputs, Auto Switchover	48V/50A/500/AUTO

 **Note**

SCU can monitor multiple power systems made by Emerson. If the system type is not set correctly, unpredictable faults may occur.

### 5.7.11 Alarm Settings

1. The first page of the setting interface is show below:

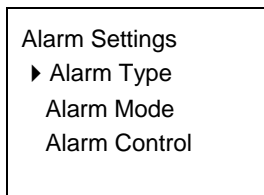

There are 3 submenus. Use “▼” or “▲” to select one, and use “ENT” to confirm.

2. The three submenus are shown below:

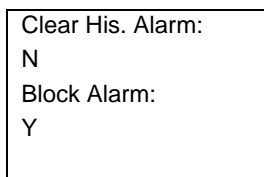
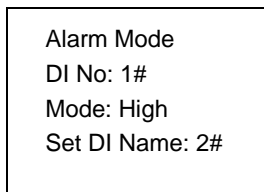
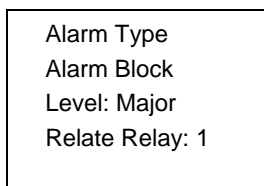



Use “▼” or “▲” to select one page or one of the parameters, and “◀” or “▶” to select the parameter value. Press “ENT” to confirm and save.

3. After setting the “Set DI Name” and confirming it, the system will prompt you to name the DI:

DI Name ▶ Digital 1
------------------------

Use “▼” or “▲” to change the number, and “◀” or “▶” to move the cursor left or right. Press “ENT” to confirm.

4. The value description of the parameter is listed below:

*Table 5-20 Value description of alarm settings*

Parameter	Range	Default	Value description	
Alarm Type	56 names of alarm events	Alarms of different	Select those alarm events whose levels and relate relays should be reset	
Level	Critical, Major, Observation, None	types have different	There are different audible/visual alarm modes and callback modes for alarm events of different levels	
Relate Relay	Empty, No.1 ~ 8	levels and different Relate Relays	“Empty”: The corresponding dry contact will not output alarm information upon an alarm event “No. 1 ~ 8”: There will be a dry contact in the range of No.1 ~ 8 that outputs the alarm information upon an alarm event	
DI No.	No. 1 ~ 8	1	The 8 corresponding connecting terminals, queued up in the order that the hardware switches are put	Effective only to self-defined DI alarms
Alarm Mode	High, Low	Low	“High”: alarm upon high level; “Low”: alarm upon low level. Set according to the actual situation	
Set DI Name	1# ~ 8#	1#	Serial No. of the connecting terminal for DI input	
DI Name	Figures or letters, 10 at most	Digital	When there are DI alarms, this parameter shows the alarm name you have actually defined. In the system with an AC sampling board, you can define by yourself the DIs of routes No.7 and No.8. In the system without an AC sampling board, you can define all DIs	
Clear His Alarm	Y, N	N	“Y”: Delete historical alarms	
Block Alarm	Y, N	N	“Y”: The active alarms will not be sent to the host (valid in EEM protocol)	

## Chapter 6 Routine Maintenance

### 6.1 Maintenance Of Rectifier

The fan of rectifier shall be maintained periodically.

The fan shall be replaced if it does not work due to faults.

Follow the procedures below to replace the fan:

1. Loosen the 3 screws on the baffle and remove the baffle.
2. Unplug the power cable of the fan and remove the fan.
3. Replace the fan.
4. Plug the fan power cable back into the corresponding socket.
5. Push back the fan (the side with the tag facing inward).
6. Mount the front baffle and fix it with screws.

### 6.2 Maintenance Of SCU

If any SCU fault affects the normal operation of DC power system, just turn off the SCU.

### 6.3 Maintenance Of MFU

1. Short-circuit of load

If some of the loads have short circuit fault, just turn off the circuit breakers in the MFU to disconnect the power to the loads.

2. MFU short-circuit

When MFU short-circuit occurs, disconnect the AC power supply, isolate the batteries from the system, and then use battery or rectifier to directly supply power to load.

---

## 6.4 Cover Plates

The Multi-Function Unit has a cover plate to protect the load and battery circuit breakers and to create a neat finish. This cover plate is easy to open/remove in order to switch on or off a circuit breaker, or to connect additional loads. The cover plate can be opened or removed without the need of using special tools. The DC section of the Distribution Unit is made safe for a “User” to access, which follows the “Look and Feel” guidelines.

## 6.5 Battery Maintenance

### 6.5.1 Storage And Supplementary

During storage, the capacity of the battery decreases because of self-discharging. When using a stored battery, always carry out supplementary charging before use. Refer to the battery user manual or follow battery manufacturer’s advices to perform supplementary charging.

Store the battery in a cool dry place.

### 6.5.2 Daily Inspection

1. Check the battery regularly. The battery needs to be replaced if any abnormal condition occurs, such as:

Any voltage abnormalities;

Any physical defects (e.g., a cracked or deformed container cover);

Any electrolyte leakage;

Any abnormal heat generation.

2. Clean any dust contamination with a wet cloth. Never use organic solvents (gasoline or thinners), otherwise the container or cover may crack.

3. Voltage checks.

Total voltage

The total voltage of the batteries should not deviate from the recommended 2.25 V per cell (54V in a 48V DC power system at reference temperature). If it deviates, check your system to see that the setting is correct and that the temperature compensation is correct.

Unit voltage

After one year of operation, all the units should be within the range of  $13.50\pm 0.48\text{V}$ .

### 6.5.3 Replacement

#### 1) Replacing Criterion

Replace the battery if its capacity measured during the battery test is less than 80% of the battery rated capacity. The capacity measured during the battery test shall be evaluated at a discharge rate close to its actual use.

#### 2) Replacement Interval

The battery is expendable, and has a certain life cycle. Considering the use condition and ambient temperature, the new battery should replace the old battery before it reaches its design life to ensure the normal and safety operation of the DC power system. For instance, in an environment where the mean temperature is  $35^{\circ}\text{C}$ , it is necessary to replace the battery every 5-year operation.

## Chapter 7 Troubleshooting

### 7.1 Troubleshooting Rectifier

#### 1. Troubleshoot Rectifier according to LED Indication

The usual fault symptoms of the rectifier include: power indicator (green) off, protection indicator (yellow) on, protection indicator (yellow) blinking, alarm indicator (red) on, and alarm indicator (red) blinking.

*Table 7-1 Troubleshooting*

Symptom	Cause	Suggestion
Power indicator (green) off	No input voltage	Make sure there is input voltage
	Input polarity reversed or input fuse blown	Replace the fuse with a new one of the same model or reconnect the input power with correct polarity.
Protection indicator (yellow) on	AC input voltage outside the normal range	Ensure the AC input voltage remain within normal range
	PFC over-voltage	Replace the rectifier
	Current sharing function is disabled	Replace the rectifier
	Rectifier over-temperature protection, which is caused by:	
	1. Fan blocked	1. Remove the obstacle that blocks the fan
	2. Ventilation blocked: the inlet or outlet blocked	2. Remove the objects that blocks the inlet or outlet
	3. Ambient temperature too high or rectifier inlet too close to an heater	3. Remove the heater, lower the ambient temperature
Rectifier not inserted into the slot completely	Insert the rectifier again properly	
Protection indicator (yellow) blinking	Rectifier communication failure	Check the communication cables
Alarm indicator (red) on	Rectifier over-voltage	Remove the rectifier from the DC power system, restart the rectifier, and replace the rectifier if over-voltage still occurs.
Alarm indicator (red) blinking	Fan not running	Replace the fan

#### 2. Rectifier Current Sharing Unbalanced

When multiple rectifiers are in parallel connection and the unbalance of current sharing among them is bigger than 3%, check if the communication cables are correctly connected.

If the current sharing is still unsuccessful after the correction, replace the rectifier of which the current sharing function is disabled.

## 7.2 Mains Failure

Mains failure often occurs in power system operation. Batteries will provide backup DC power in case of short-period of mains failure. If the cause of mains failure remains unknown or the failure lasts too long, the generator should be started to provide mains supply to the system. It is suggested that the generator should supply power to the power system at least 5 minutes after it is started so as to reduce the effect of the start process on the power system.

## 7.3 Disastrous Accidents

Disastrous accidents such as lightning strike, flood, earthquake and fire lead to the communication equipment faults. For the disasters that will severely affect the safety of communications, efforts should be mainly made to prevention actions. Meanwhile, communication stations should have adequate human and material resources and work out effective countermeasures to cope with these disasters. They should also have emergency management regulations and serious accidents emergency plans.

## Appendix 1 System Technical Parameters

Parameter	category	Note
AC input alarm and protection	AC input over-voltage alarm point	Default: 280 ! 5Vac, configurable through monitoring module
	AC input over-voltage recovery point	Default: 270 ! 5Vac, 10Vac lower than the AC input over-voltage alarm point
	AC input under-voltage alarm point	Default: 180 ! 5Vac, configurable through monitoring module
	AC input under-voltage recovery point	Default: 190 ! 5Vac, 10Vac higher than the AC input under-voltage alarm point
DC output alarm and protection	DC output over-voltage protection point	Default: 59.0 ! 0.2Vdc
	DC output over-voltage alarm point	Default: 58.5 ! 0.2Vdc, configurable through monitoring module
	DC output over-voltage recovery point	Default: 58 ! 0.2Vdc, 0.5Vdc lower than the over-voltage alarm point
	DC output under-voltage alarm point	Default: 45.0 ! 0.2Vdc, configurable through monitoring module
	DC output under-voltage recovery point	Default: 45.5 ! 0.2Vdc, 0.5Vdc higher than the under-voltage alarm point
	LLVD	Default: 44 ! 0.2Vdc, configurable through monitoring module
	BLVD	Default: 43.2 ! 0.2Vdc, configurable through monitoring module
	Output delay	Output voltage can rise slowly upon rectifier start up. The rise time is configurable
	Fan speed adjustable	Rectifier fan speed can be set to half or full speed.
EMC	CS	EN300386 2001, Class A
	RS	
	Immunity to EFT	EN61000-4-4, Level 3
	Immunity to ESD	Air discharge: 8kV. Contact discharge: 4kV. EN61000-4-2
	Immunity to Surges	EN61000-4-5, Level 4
Lightning protection features	At AC side	The AC input side can withstand 10/700 $\mu$ s simulated lightning voltage 5kV for !5 times, or 8/20 $\mu$ s simulated lightning surge current 20kA for !5 times, or 8/20 $\mu$ s simulated lightning surge current 40kA once. The test interval is not smaller than 1 minute.
Others	Acoustic noise	□ 55dB (A)
	Insulation resistance	At temperature of 15°C ~ 35°C and relative humidity not higher than 90%RH, apply a test voltage of 500Vdc. The insulation resistances between AC circuit and earth, between DC circuit and earth, or between AC and DC circuits are no less than 10M $\Omega$

Parameter	category	Note		
Others	Dielectric strength	(Remove the SPD, monitoring module and rectifiers from the system before the test.) AC to DC circuits, AC circuit to earth: 50Hz, 3,000Vac (RMS). DC circuit to earth: 50Hz, 1,000Vac (RMS). Assistant circuit (not directly connected to the host circuit): 50Hz, 500Vac (RMS). For all the three tests above, there should be no breakdown or flashover within 1min, with leakage current not bigger than 10mA.		
	MTBF	250,000hr		
Mechanica	Size (mm)	600 (W) % 600 (D) % 2000 (H)	600 (W) % 400 (D) % 2000 (H)	600 (W) % 400 (D) % 700 (H)
	Weight	<135kg (without rectifiers)	<125kg (without rectifiers)	<60kg (without rectifiers)



## Appendix 2 Engineering Design Diagram

### Appendix 2.1 Engineering Design Diagram For 2000mm%600mm%600mm Cabinet

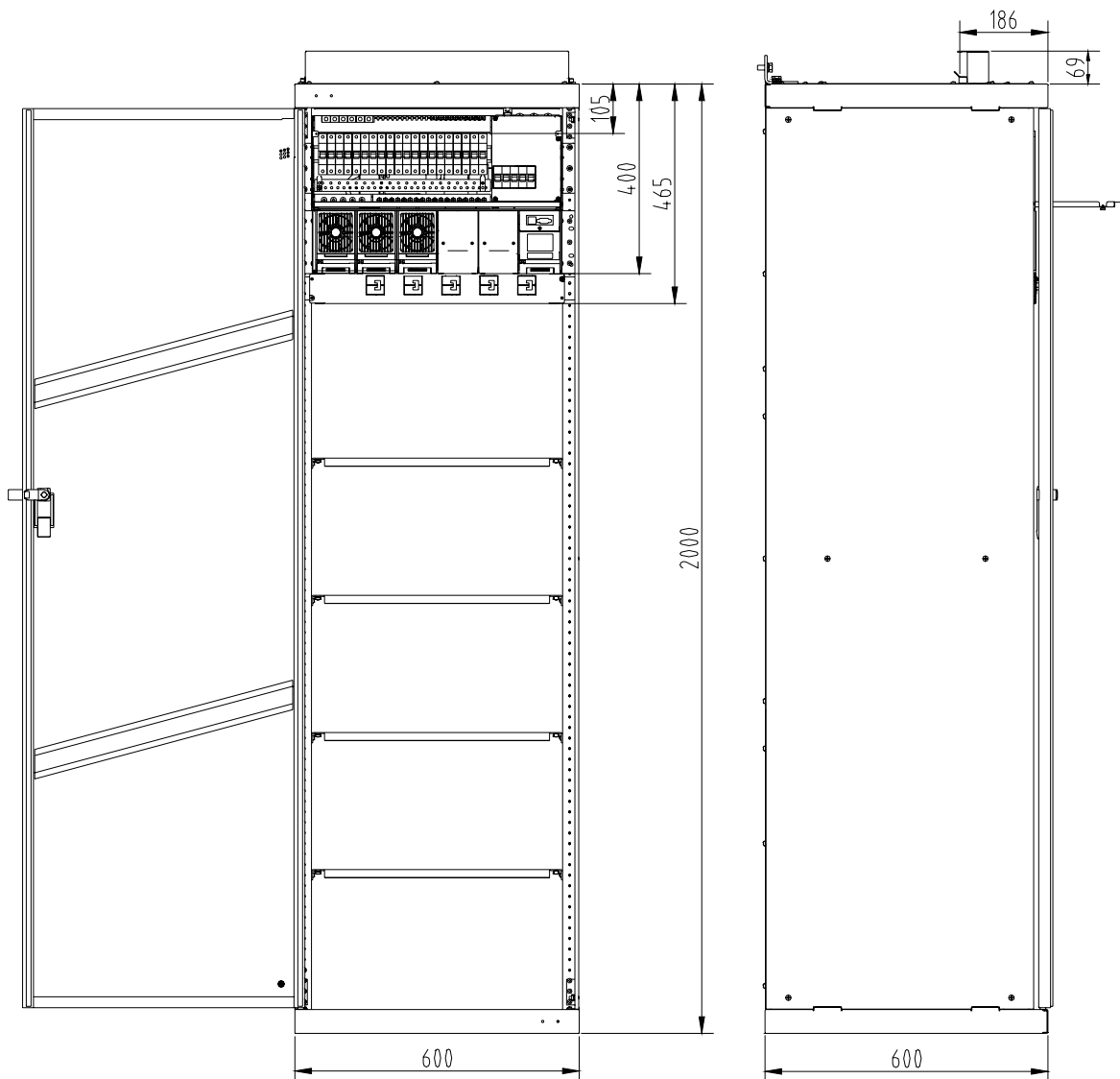

## Appendix 2.2 Engineering Design Diagram For 2000mm%600mm%400mm Cabinet

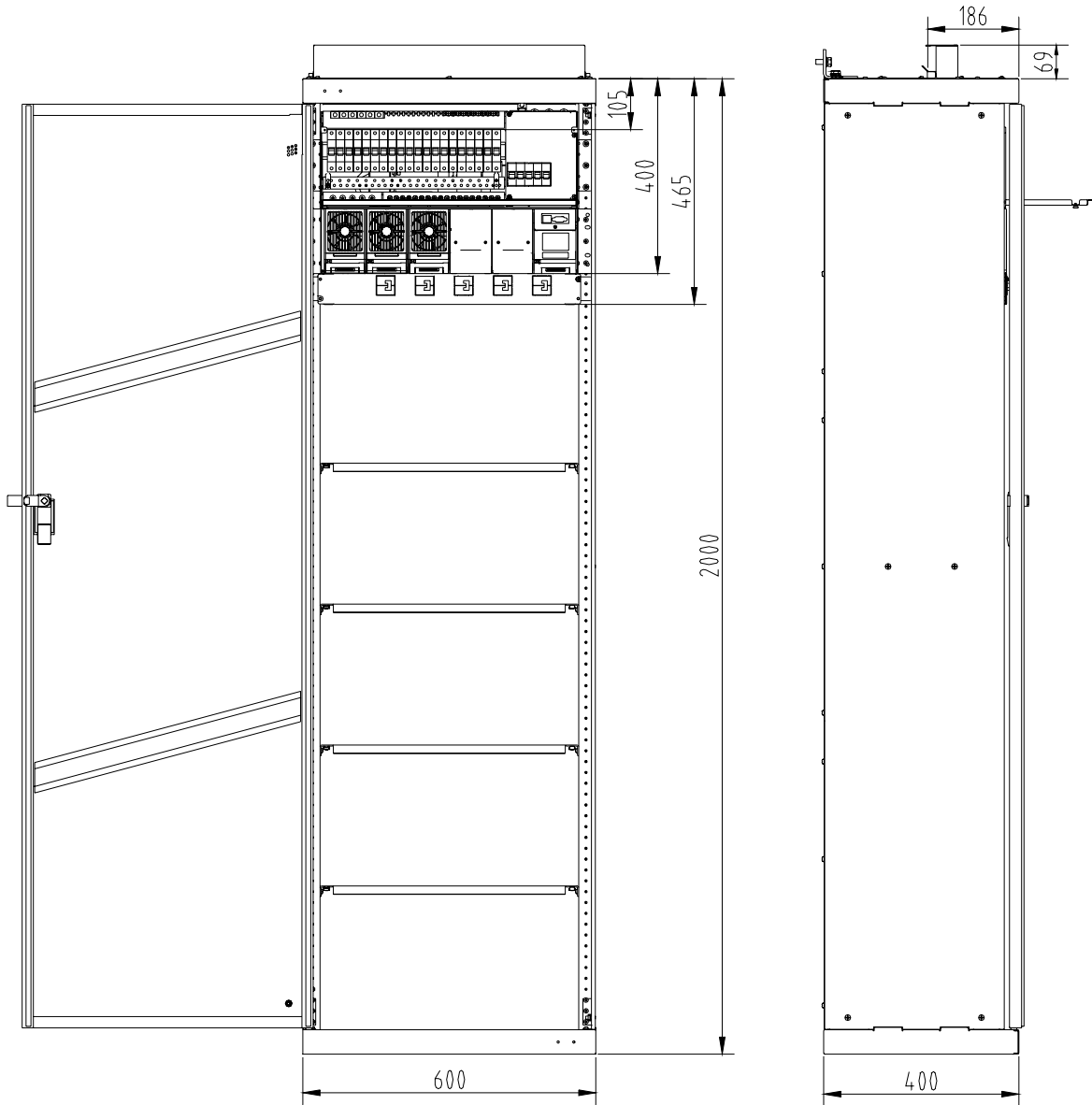

## Appendix 2.3 Engineering Design Diagram For 700mm%600mm%400mm Cabinet

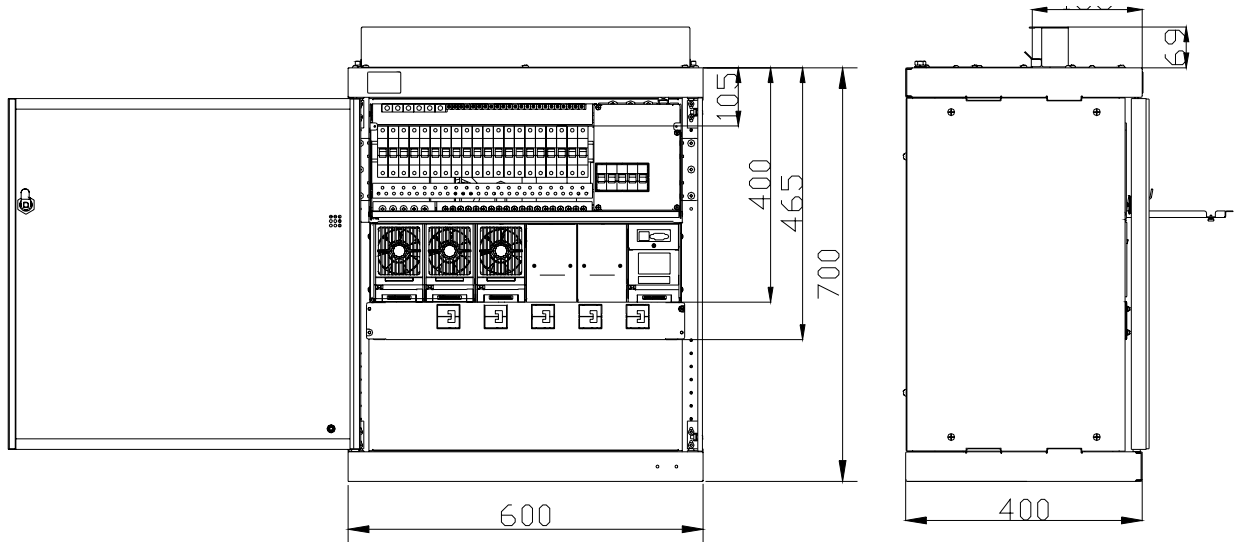

## Appendix 2.4 System Input And Output Connector Specs

Connector		Connector specs	
AC Power distribution	AC input terminal	H cable terminals, 2-4 pcs (cable section $\square 35\text{mm}^2$ )	
	Grounding busbar	1 M8 bolt	
1 big wire connectors, (cable section $\square 25\text{mm}^2$ )			
DC Power distribution	Positive bus bar	4 M8blots, 6 big wire connectors, (cable section $\square 25\text{mm}^2$ ) 23 small wire connectors, (cable section $\square 16\text{mm}^2$ )	
	Output route	MCB	H cable terminals (cable section $\square 25\text{mm}^2$ )

# Appendix 3 System Circuit Diagram

## Appendix 3.1 System Electric Schematic Diagram

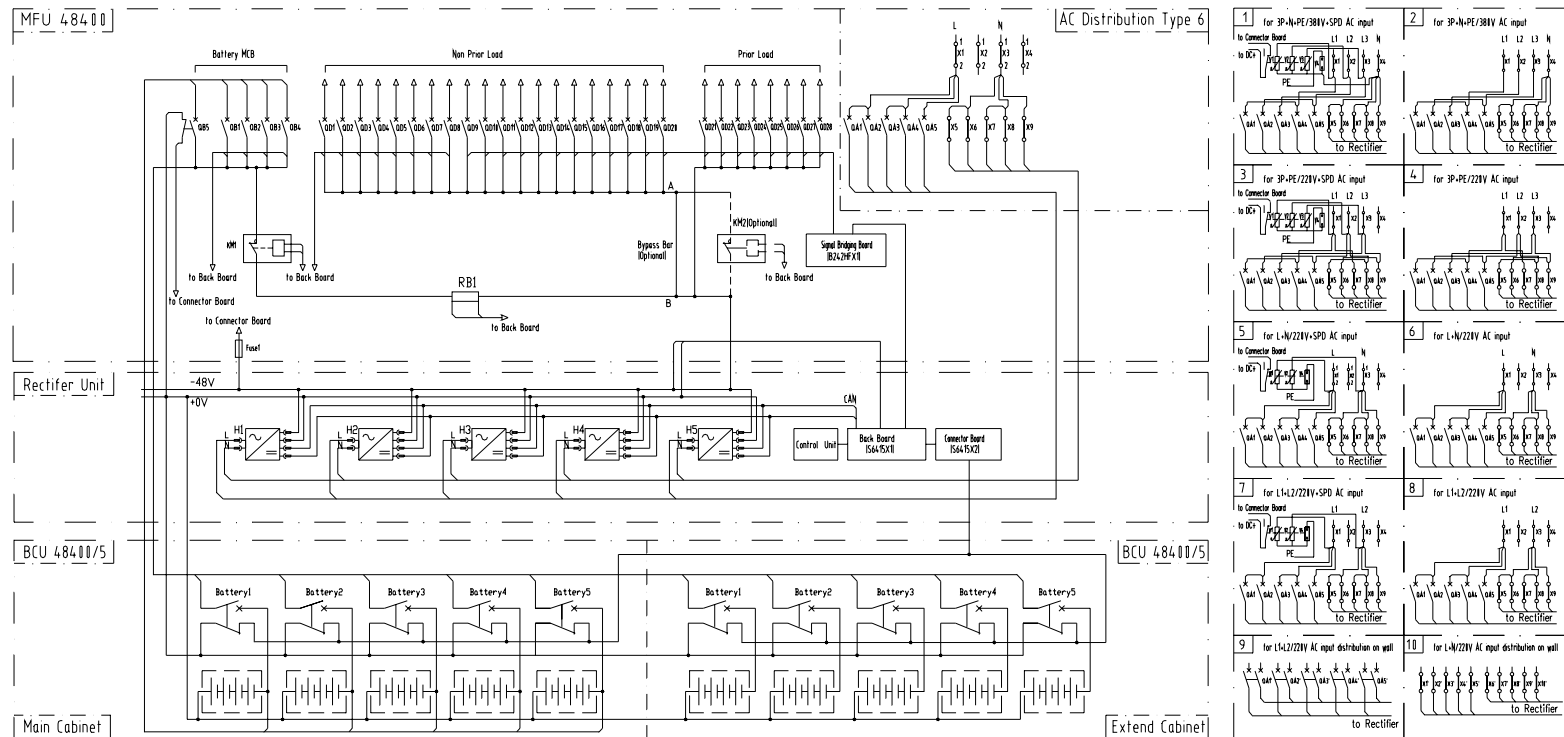

## Appendix 3.2 System Wiring Diagram

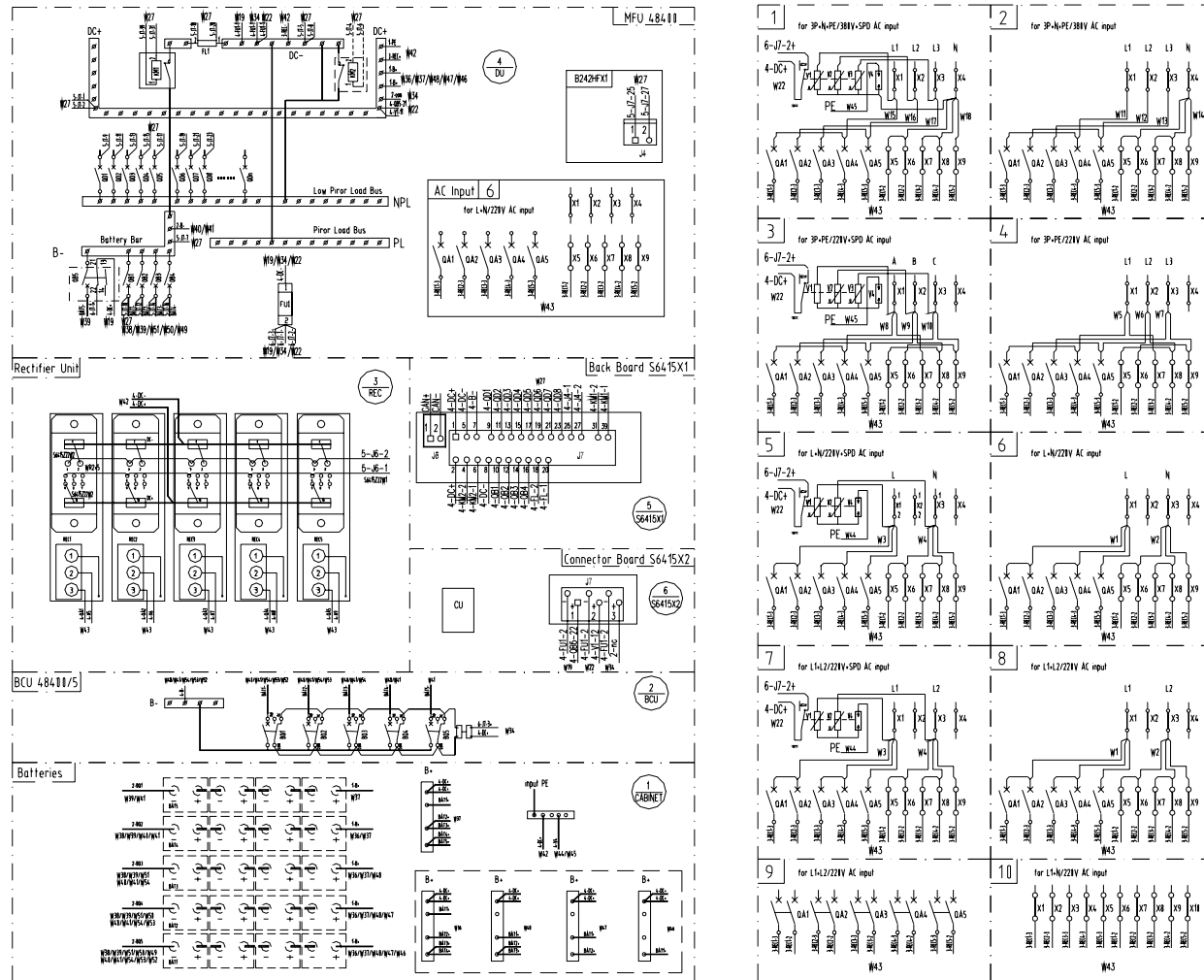

### Appendix 3.3 MFU Electric Wiring Diagram

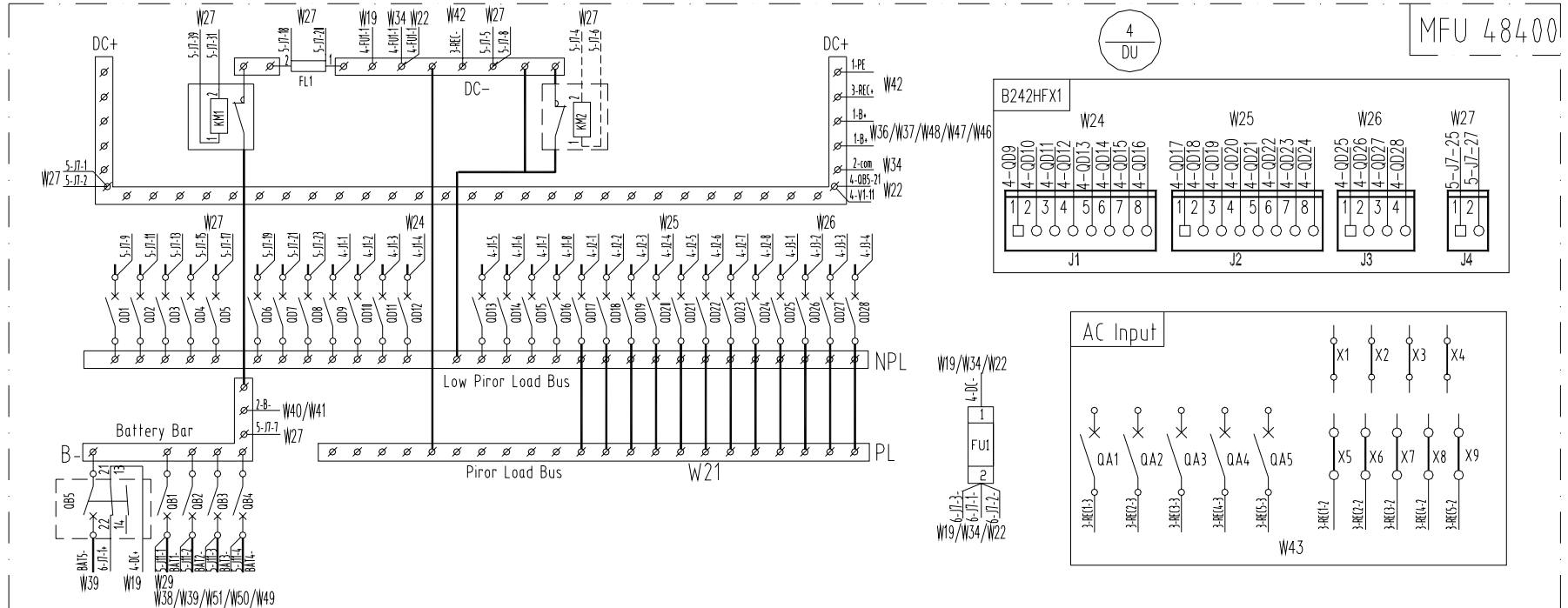

### Appendix 3.4 BCU Electric Wiring Diagram

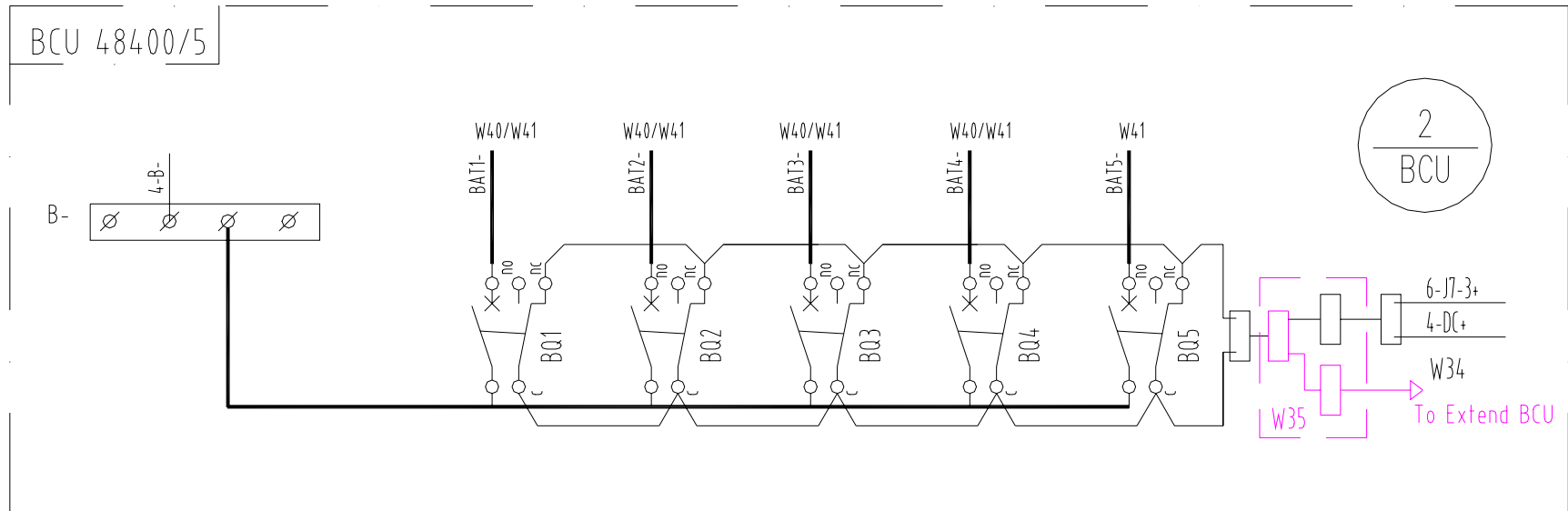

## Appendix 4 Glossary

Abbreviation	Full word
Amb.Temp	Ambient Temperature
Batt	Battery
BC	Boost Charging
BLVD	Battery Lower Voltage Disconnection
Cap	Capacity
CommMode	Communication Mode
CurrLimit	Current Limit
CycBC	Cyclic Boost Charging
Con Alarm Voice	Control Alarm Voice
Hist Alarm	Historical alarm
HVSD	High Voltage Shutdown
InitParam	Initialize Parameters
InitPWD	Initialize Password
LLVD	Load Low Voltage Disconnection
LVD	Low Voltage Disconnection
Ph-A	Phase A
PWD	Password
Rect	Rectifier
Shunt coeff	Shunt Coefficient
SPD	Surge Protection Device
SW Version	Software Version
Sys	System
Temp	Temperature
Temp Comp	Temperature Compensation
Volt	Voltage